

lasting strength
with fibre-cement

nutec
ROOFING AND CLADDING SOLUTIONS

Manufactured by
EVERITE
Established in 1941

SLATE ROOFING

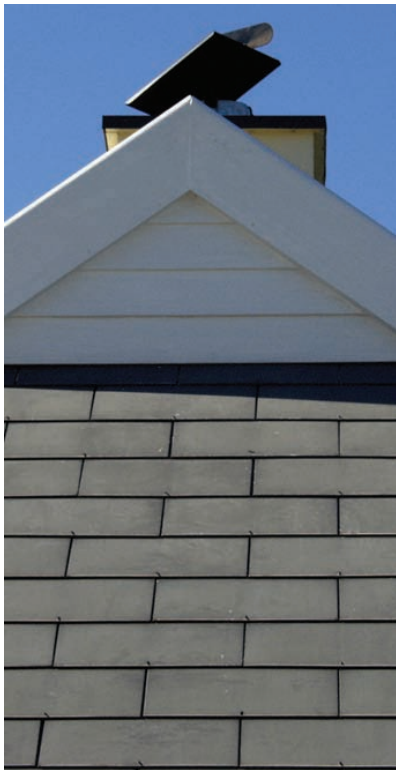



About Everite and Nutec	2
Nutec Slate Roofing	4
Nutec Roof Slates Mechanical and Physical Properties	5
Nutec Roof Slates Product Range and Dimensions	7
Accreditation	7
General Design Criteria	8
Safety, Storage and Handling Instructions	9
Recommended Slating Tools	11
General Installation Guidelines	12
Supporting the waterproofing membrane	12
Preparing the roof for Fixing Battens	14
Fixing and levelling of Battens	15
Squaring the Roof	16
Marking out the Battens for Slating	16
Trimming of Battens	18
Laying of Slates	19
Fixing the Ridge	21
Constructing an Open Valley	22
Construction of a Closed Valley	23
Constructing a Raised Boston Hip	25
Flashing around a Chimney	27
Special Flashing Details	28
To replace a damaged Roof Slate	29
Nutec Slate Fixing Accessories	30
Estimating Quantities	31
Everite National Offices and Contact Details	36

Catalogue Information

The information contained in this catalogue serves as a general guide only and should not be accepted as the standard for all construction. EVERITE can assist in designs of a special nature, however, architects, engineers and specifiers must finally approve the acceptability in terms of the design and construction criteria, as well as other implications.

About Everite and Nutec

■ Everite Building Products

Everite Building Products, has been associated with the South African building industry since 1941. Producing a wide range of materials that satisfy the needs of the commercial, industrial and residential market sectors, Everite is renowned for its comprehensive range of Nutec Roofing and Cladding Solutions and includes fibre-cement roofing, cladding, ceilings and building columns amongst others.

Nutec fibre-cement high performance properties and added benefits include: the use of safe renewable fibres; considerable tensile strength with enhanced dynamic load bearing properties; excellent thermal properties; water and wind resistance; hail resistance; fire resistance and resistance to fungus, rodents and acid.

A programme of quality assurance in accordance with the requirements of the International Standards Organisation (ISO 9001:2015) is entrenched in Everite's process and management systems. Quality of all products is continuously monitored as specified by the South African National Standards and recognised international bodies.

Everite's 54 hectare manufacturing facility near Johannesburg is well located and has immediate access to all major road and rail links to national destinations and major ports. The company has branches located at major centres throughout South Africa. Nutec products are distributed through leading stockists countrywide and an established export market further endorses the international acceptance of the Nutec Roofing and Cladding Solutions range of products.

■ Nutec

Nutec is the registered name for products manufactured without asbestos as a raw material. Nutec fibre cement products are manufactured using a mixture of cellulose fibre, cement, silica and water.

Through ongoing research and development, Everite Building Products are committed to provide product of world-class quality.

Accordingly, the Nutec product range is continuously reviewed not only in the interests of the end-user and superior product performance, but also with respect to its impact on the environment. Everite Building Products has over the years established a reputation for producing a variety of outstanding quality products which have been used in a wide range of external and internal applications.

Environmental benefits of Nutec Fibre Cement

- Environmental costs incurred by using fibre cement are measurably less than for other building materials. (Low embodied energy per m²).
- Requires less energy in assembly and construction than all other wall materials except timber.
- Low energy consumption in transportation and installation.
- Environmental costs relating to ozone layer depletion, carcinogenic substances and solid waste emissions are almost negligible.
- Low environmental impact in relation to ozone layer depletion, carcinogenic substances, and solid waste emissions.
- No pesticides are involved in the manufacture or use of fibre cement.

The benefits of Nutec Fibre Cement

- The use of safe fibres.
- Considerable tensile strength with enhanced dynamic load bearing properties.
- Cost competitive.
- Excellent thermal properties.
- Water tight and wind resistant.
- Hail resistant.
- Fire-resistant.
- Fungus and rodent resistant.
- Acid resistant.
- Complies with SABS ISO 9933.
- ISO 9001 : 2015 Quality Management System.

The environmental benefits in the manufacturing process of Nutec Fibre Cement

- Recycling the water used in production many times.
- Recycling solid wastes.
- Using sustainable raw materials in production.

Embodied Energy – Definition

Embodied energy is the energy consumed by all of the processes associated with the production of a building, from the mining and processing of natural resources to manufacturing, transport and product delivery. Embodied energy does not include the operation and disposal of the building material. This would be considered in a life cycle approach. Embodied energy is the 'upstream' or 'front-end' component of the lifecycle impact of a home. Fibre cement is one of the most energy efficient materials on the market and it has one of the lowest embodied energy contents per square metre of cover of any building product.

FEATURES

Nutec Slate Roofing

Nutec Roof Slates form part of the Nutec roofing range which includes the Nutec Bigsix and Nutec Victorian roofing profile. Favoured for more than seven decades in all sectors of the building industry, the range is renowned for years of trouble free roofing and offers designers and specifiers freedom and flexibility when functional, aesthetic and cost criteria need to be met.

Nutec Roof Slates are the ideal roofing or cladding material to use on any project where class, character and individuality are of prime importance. The precise detail of the application and consistent appearance ensure an excellent finish.

■ Features

Finish and Colour

Nutec Roof Slates are available in a plain or textured finish and a range of standard roofing colours. This provides designers creativity and individuality of expression, whether recreating old-world charm or meeting today's critical architectural design criteria. Nutec Roof Slates are factory coated with a specially developed paint system. Natural weathering will cause the paint coating to fade over time. Inspection and re-coating of the roof recommended after seven (7) years.

Economical

Their light mass requires a correspondingly light supporting structure, thereby offering an economical alternative to other slate and roofing materials and can be used for vertical cladding applications. Nutec Roof Slates by nature do not corrode and are unaffected by ultraviolet light.

Thermal Insulation

Nutec Roof Slates have excellent thermal properties. Thermal Conductivity (K-Value) of the Nutec material is approximately 0.3 W/m.K or 0.3 W/m.°C. (Test method ASTM C518)

Fire Resistant

Nutec Roof Slates are Non-Combustible and have a Class 1 Spread of Flame Index when evaluated in accordance with SANS 10177: Parts V and II respectively. The product can be used in applications with continuous temperature not exceeding 150°C.

Rodent and Termite Resistance

Nutec Roof Slates have been tested in accordance with SANS 5419 for Rodent Resistance and awarded a rating of Class B1.

No damage was recorded when tested for Termite Resistance in accordance with SANS 5471.

Water Tightness

Nutec Roof Slates in their natural state pre coating are non-permeable when tested in accordance with SANS 685. Darkening is normal because of moisture absorption but no droplets form.

MECHANICAL AND PHYSICAL PROPERTIES

Nutec Roof Slates Mechanical and Physical Properties

Parameter	Unit	Plain & Textrata Slates	Test Method
DIMENSIONS			
Thickness Tolerance:	mm	± 0.8	SANS 803
Length Tolerance:	mm	± 3	SANS 803
Width Tolerance:	mm	± 3	SANS 803
Squareness	mm	3	SANS 803
Edge Trueness	mm/m	3	SANS 803
PHYSICAL PROPERTIES			
Minimum MOR : With Grain	MPa	7.40 ⁽¹⁾	SANS 803
Minimum MOR : Across Grain	Mpa	10.60 ⁽¹⁾	SANS 803
Target Density	g/cm3	1.26	ISO 8336
Maximum Hygral Linear Expansion	mm/m	2.47	SANS 803
Thermal Conductivity	W/m.K	-	ASTM C518
Thermal Expansion Coefficient	(20 - 70)°C-1	Negligible	SANS Document 722/W 1009
Moisture Movement			
With Grain	%	0.06	ASTM C1185
Across grain	%	0.06	ASTM C1185
Moisture Content	%	6.3	ASTM C1185
Water Absorption	%	37.72	ASTM C1185
Permeability	-	No droplets formed	SANS 685
pH	-	12	
MECHANICAL PROPERTIES			
MOR: With Grain	Mpa	4.20 ⁽²⁾	ASTM C1185
	Mpa	7.50 ⁽³⁾	ASTM C1185
MOR: Across Grain	Mpa	7.75 ⁽²⁾	ASTM C1185
	Mpa	12.10 ⁽³⁾	ASTM C1185
Classification in accordance to ASTM C1186			
Compressive Strength parallel to Surface of Board			
With Grain	Mpa	10.56 ⁽²⁾	ASTM D1037
	Mpa	15.57 ⁽³⁾	ASTM D1037
Across Grain	Mpa	11.54 ⁽²⁾	ASTM D1037
	Mpa	19.58 ⁽²⁾	ASTM D1037
Tensile Strength Perpendicular to Surface of Board			
	Mpa	0.83 ⁽²⁾	ASTM D1037
	Mpa	1.02 ⁽³⁾	ASTM D1037
Young's Modulus (E.Mod)			
With Grain	Mpa	5337 ⁽³⁾	ASTM C120
	Mpa	3974 ⁽²⁾	ASTM C120
Across Grain	Mpa	6474 ⁽³⁾	ASTM C120
	Mpa	4681 ⁽²⁾	ASTM C120
Block Shear Strength			
	Mpa	1.60 ⁽²⁾	ASTM D143
	Mpa	1.32 ⁽³⁾	ASTM D143

(1) Dried till constant weight (2) Saturated with water (3) Equilibrium conditions

MECHANICAL AND PHYSICAL PROPERTIES

Nutec Roof Slates Mechanical and Physical Properties

Parameter	Unit	Plain & Textrata Slates	Test Method
OTHER PROPERTIES			
Fire Properties Fire Index	Class	1	SANS 10177: Part II, BS 476: Part 7
Non-Combustibility		Non combustible	BS 476: Part 4, SANS 10177:Part V
Continuous Temperature	-	150°C	
Frost Resistance			
Cycles Completed	-	50	ASTM C1185
Strength Ratio	%	78.5	ASTM C1185
Biological Resistance			
Rodent Resistance	Class	B1	SANS 5419
Termite Resistance	-	No Damage	SANS 5471

(1) Dried till constant weight (2) Saturated with water (3) Equilibrium conditions

PRODUCT RANGE AND DIMENSIONS

■ Nutec Roof Slates Product Range and Dimensions

SLATES

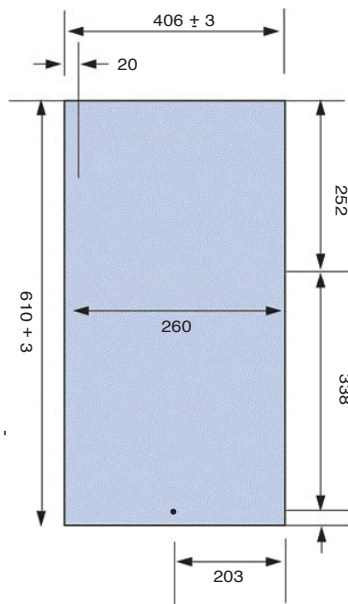

All dimensions in mm.

Rectangular Plain Mitred and Un-Mitred

Size	610 mm x 406 mm
Thickness	7 mm
Slates per m²	10
Mass per Unit	2 kg
Mass per m²	± 21 kg

Product No. Colour / Mitred

020-901	Black
020-902	Charcoal
020-901	Cloud Grey

Product No. Colour / Un-Mitred

020-951	Black
020-952	Charcoal
020-951	Cloud Grey

Non Stock Items

Rectangular Textrata Un-Mitred

Size	610 mm x 406 mm
Thickness	7 mm
Slates per m²	10
Mass per Unit	3 kg
Mass per m²	± 24 kg

Product No. Colour / Un-Mitred

020-802	Black
020-824	Charcoal

Pressed Slates (610 mm x 406 mm x 5 mm thick) are available on request for replacement purposes only.

Accreditation: SABS, SANS & ISO

Nutec Slates carry the SABS Mark under specification SANS 803.

Everite is an accredited ISO 9001:2015 Quality Management System listed company.

DESIGN CRITERIA

General Design Criteria

High Wind Conditions

The information presented in this catalogue is a guide for wind loading conditions. A structural engineer should be used for design purposes to ensure that spans, fixing details and roof pitches meet the requirements for the particular conditions.

Ventilation

Climatic conditions in certain parts of Southern Africa are such that condensation may occur on the underside of the roofing slates. It is therefore recommended that the space between the ceiling and the roofing slates is adequately ventilated.

Purpose-made ventilating slates can be manufactured for situations where no other form of ventilation can be accommodated.

Roof Pitch

Nutec Roof Slates are designed for a minimum roof pitch of 17,5°. In high wind areas the slates may no longer provide a waterproof covering and a waterproof underlay must be installed. *Refer Fig. 2*, for more details. It is recommended that the pitch be increased as specified by the structural engineer or architect.

Substructure

A high standard of finish can be achieved if the supporting structure is accurate and level. Warped, twisted or poor quality battens or sagging roof trusses will reflect adversely in the finished plane of the roof. Use only well seasoned graded structural timber.

To ensure that lines are true and the laps uniform, battens must be fixed exactly to the spacing specified.

The batten sizes required for the various rafter/truss spacing and for the different slate sizes are given in *Table 1*.

Fixing Accessories

Fixing accessories in the form of galvanised and copper clout nails as well as copper disc rivets have been specially developed for Nutec Roof Slates. Full details are scheduled under Fixing Accessories.

Do not allow the use of non-approved, and often inferior, fixing accessories. EVERITE reserves its right to withdraw its guarantees if non approved fixing accessories are used.

Contact EVERITE sales office if in doubt.

Site Service

Service personnel are available on request to provide assistance on recommended storage, handling and erection of the EVERITE's products, before and during installation.

Safety and Handling Instructions

■ General

Manufactured from Nutec fibre-cement, Nutec Roof Slates do not contain asbestos fibre and are therefore excluded from the following:

- Asbestos Regulations of 2001, which forms part of the Act No. 85: Occupational Health and Safety.
- South African Code SANS 10229: Packaging of dangerous goods for road and rail transportation in South Africa.

Nutec Roof Slates do not pose any adverse effects on the environment. Off-cuts and dust created during site work may be disposed off on any non-hazardous waste landfill site.

■ Safety

Installation and maintenance

- **Although the Nutec Roof Slates are manufactured without asbestos fibres, it is nevertheless recommended that tools which do not create excessive dust are used when working with the product. Ordinary carpenters' hand tools can be used effectively.**
- **Use duckboards as walking areas on the roof to avoid damage to slates and injury to workers.**
- **Wear soft soled shoes for better grip.**
- **Do not carry heavy loads over completed areas of the roof or use these as staging posts for the next section.**
- **During loading of roof, do not stack more than 3 bundles (30 slates) in any one position on the roof.**
- **Do not exceed recommended purlin spacing.**

■ Storage and Handling Instructions

General Handling

Nutec Roof Slates are manufactured from a composite material containing cement and may be damaged under excessively high shock loads. Reasonable care should therefore be taken to ensure that the products are not dropped or subjected to rough handling. This is particularly important to avoid damage to the coated surface and chipping of the edges.

STORAGE AND HANDLING

Storage

- Prior to Installation Nutec Roof Slates must remain on pallets and kept under cover until installed.
- Strict stock rotation should be adhered to.

Storage On-site:

- A suitable level compacted area must be made available where Nutec Roof Slates can be stored safely so that they cannot be damaged or soiled by passing traffic.
- They must be stacked clear off the ground on suitable timber supports to a maximum height of 25 bundles (10 slates per bundle).
- **Preplanning: Adequate preplanning of deliveries should be made to ensure that Nutec products are not stored on site for excessive periods. If this is unavoidable, they should be kept under cover until installed.**

Handling

- When removing strapping from bundled slates, care should be taken that snips are used. On no account must the strapping be levered off, as this may damage the slates.
- *Refer to Fig 1* for Cutting Slate Tiles
For straight cutting of Nutec Roof Slates, a scribe or any other sharp object is all that is required to scribe the surface of the slate. The slate will break on this line if held firmly on a flat surface with a straight edge and the surplus part snapped off.

See schedule of Recommended Slating Tools.

Fig 1 : Straight cutting of Nutec Roof Slates

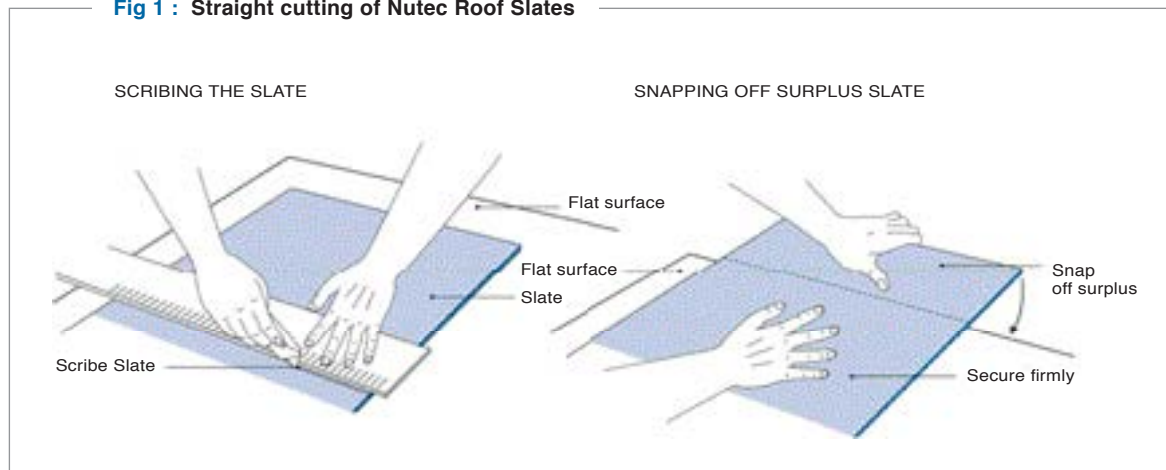

Recommended Slating Tools

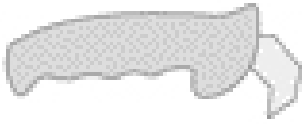
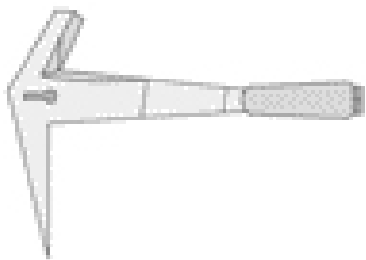
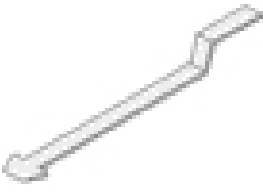
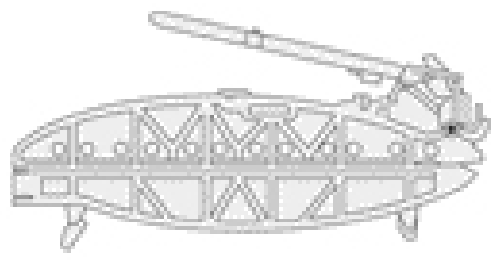
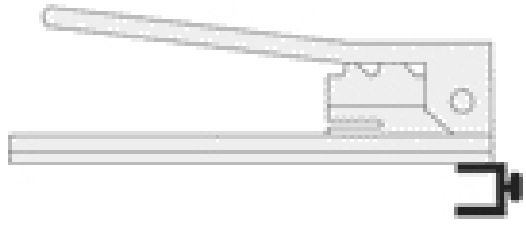
Product No.	Size Description	Sketch of Article
640-070	Scriber	
640-020	Slater's Hammer	
640-030	Slater Ripper	
640-080	Parallel Shears	
640-041	Slate Cutter Kwiksnip Slate Guillotine	

General Installation Guidelines

TABLE 1

Batten Requirements for Nutec Roof Slates		
Rafter spacing mm	Batten Sizes required mm	Batten spacing
800	38 x 38	250
950	38 x 50	250
1 100	50 x 50	250

Approximate linear metres of battens required per m² of roof laid.
 ■ 610 x 406 mm slates = 4,12 lin. m

Minimum Roof Pitch

Nutec Roof Slates are designed for a minimum roof pitch of 17,5°. In high wind areas the slates may no longer provide a waterproof covering and a waterproof underlay must be installed.

To support the waterproofing membrane, the following work is essential. Refer Fig. 2A and Fig. 2B

- Install suitable boarding or chicken wire mesh over the the rafters.
- Fix counter battens directly above the rafters on top of the boarding or chicken wire.
- Install waterproofing membrane over the counter battens, allowing it to sag onto the boarding or chicken wire between the counter battens.
- Fix slating battens over waterproofing membrane and nail through counter battens into rafter.

Fig 2A : Installation of Waterproof Underlay

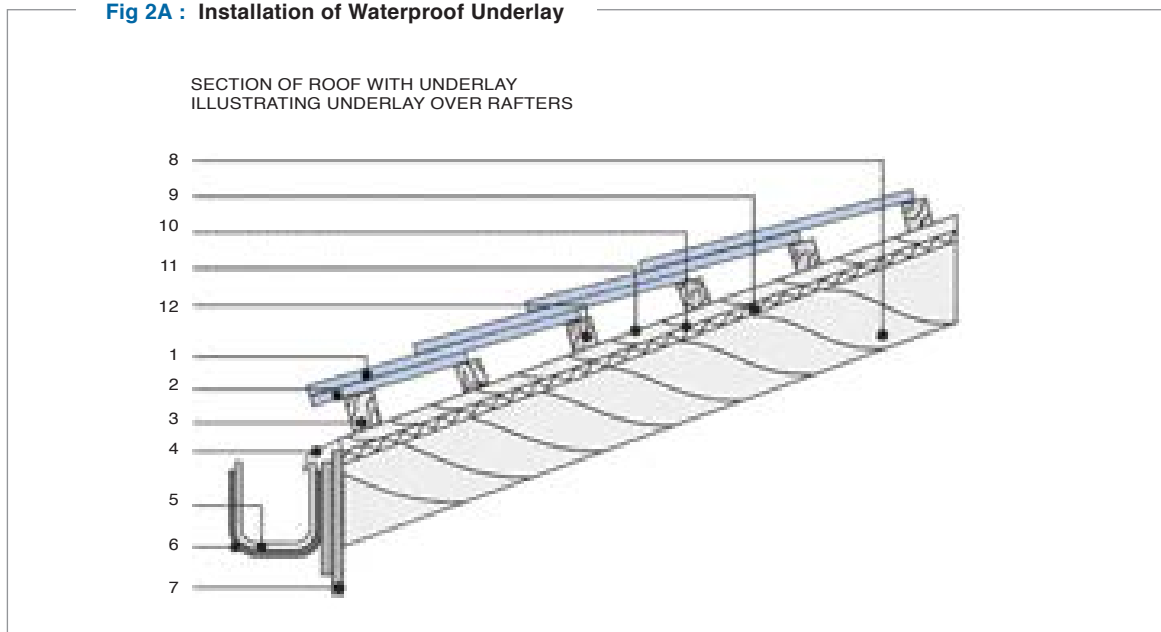
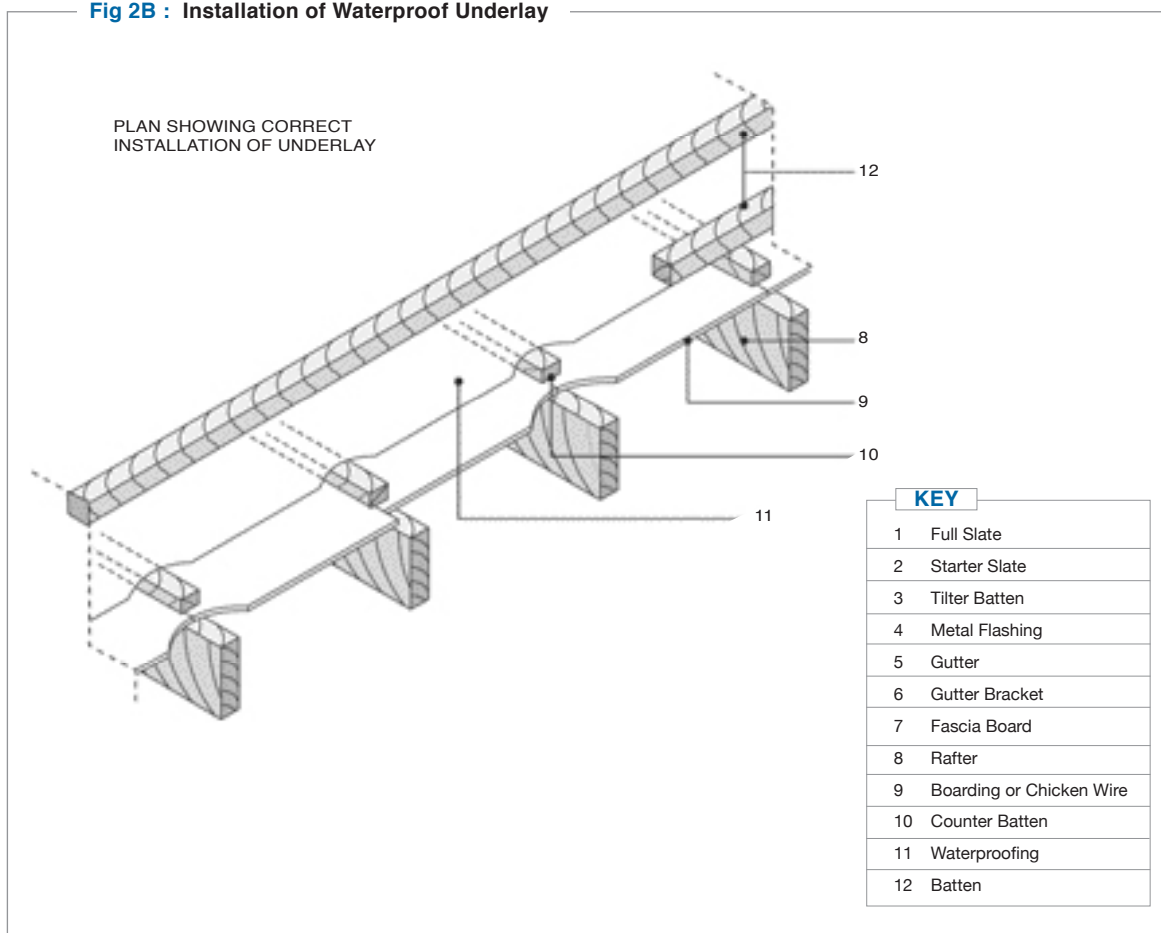

Fig 2B : Installation of Waterproof Underlay



INSTALLATION PROCEDURES

Nutec Roof Slates laid and fixed in accordance with recommendations will provide many years of trouble-free protection from the elements. It is however important to be aware of the fact that any distortion or unevenness in the roof structure and battens will reflect in the final appearance of the application. Time spent to ensure that the structure and battens are accurate and sound is therefore a small investment in the process of achieving an excellent result. The step by step erection procedure which follows will assist in this regard.

■ Step 1

Preparing the Roof for Fixing Battens

- Check that the trusses are properly lined up, correctly secured to the wallplates and that the bracing is fixed in position.
- Trim the rafter ends to overhang required to accommodate Nutec Fascia Boards where applicable.
- Install fascia boards. Refer to catalogue '**Fascias and Barge Boards**' for installation instructions.
- Install gutter brackets and gutters.

■ Step 2

Marking out the Roof for Fixing Battens *Refer Fig.5.*

Nail tilter batten in position at feet of rafters on every roof slope.

NB: Tilter batten must be 5mm higher than other battens. Using a slate, determine the overhang required from the tilter batten into the gutter for proper drainage of rainwater.

Recommended overhang is 50mm measured from the inside edge of the gutter.

Mark the rafter at the top of the slate. This will be the centre line for the third batten.

From this line up towards the ridge, mark the rafter at 250 mm centres.

Using the third batten centre line down towards the gutter, measure 250 mm for the centre line of the second batten.

Repeat this procedure for every end rafter on every roof slope.

Using a chalk line, mark all rafters accordingly.

Fig 3: Section through Roof

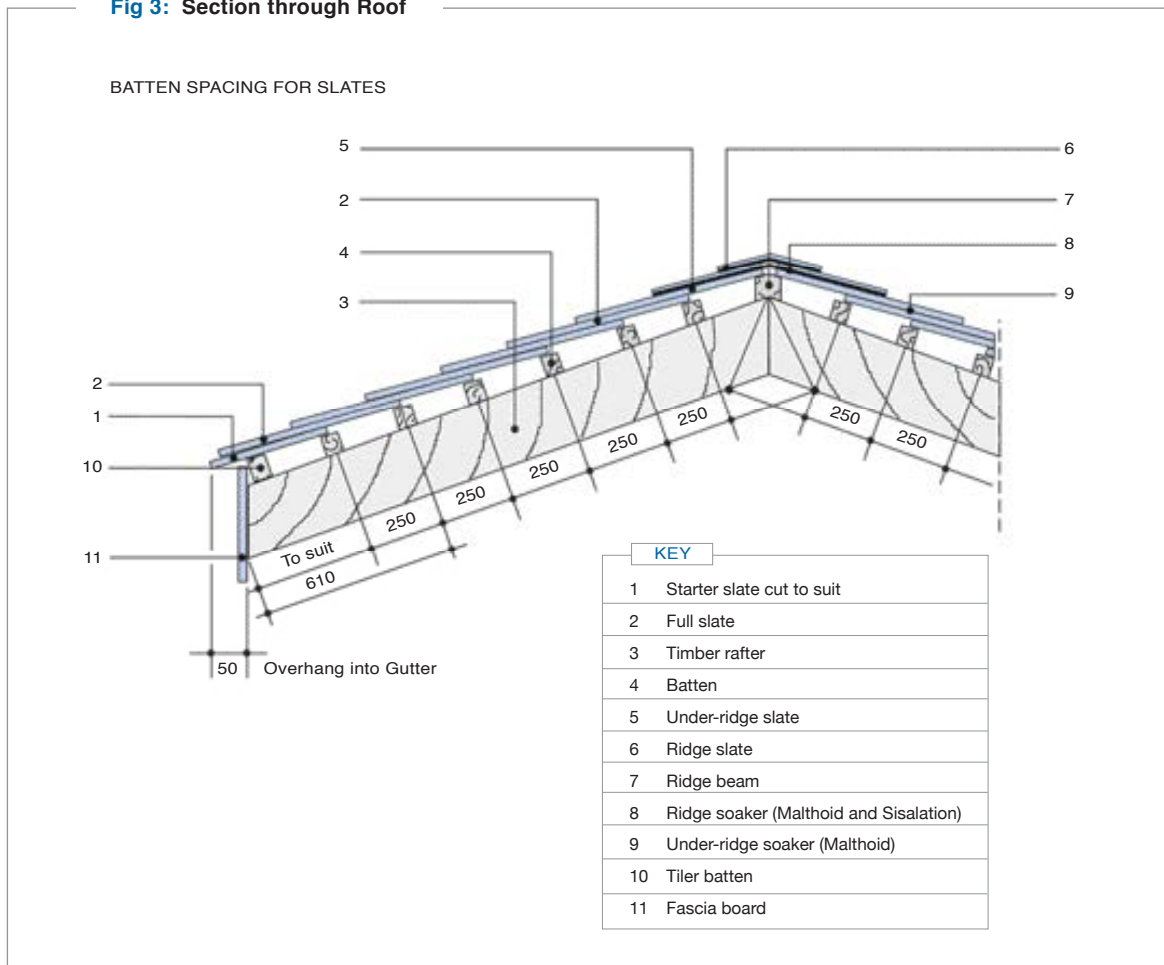

■ Step 3

Fixing and Levelling of Battens *Refer Fig. 3.*

Skew nail battens to rafters at centre lines marked, allowing adequately for the overhang required at both gable ends.

Batten butt-joints must be staggered on rafters.

Nail centre ridge batten in position.

Check evenness of roof plane by spanning a fish line across the roof in various positions.

Level battens where necessary by using wooden wedges.

NB:

- **For normal wind loading conditions nail length should be batten height plus 40 mm minimum.**
- **Where hips and valleys are encountered battens should be mitred and aligned at the intersection of the battens. *Refer Fig. 10, Fig. 11 and Fig. 12.***

INSTALLATION PROCEDURES

■ Step 4

Squaring the Roof *Refer Fig. 4*

Mark the centre of the roof slope on the tilter batten - position A.

Mark position C and D which are equal distances on either side of position A.

Select position B on the ridge batten.

Move position B until distances BC and BD are equal.

Strike a chalk line from A to B, which will be at 90° to the tilter and ridge battens.

Fig 4 : Squaring the Roof

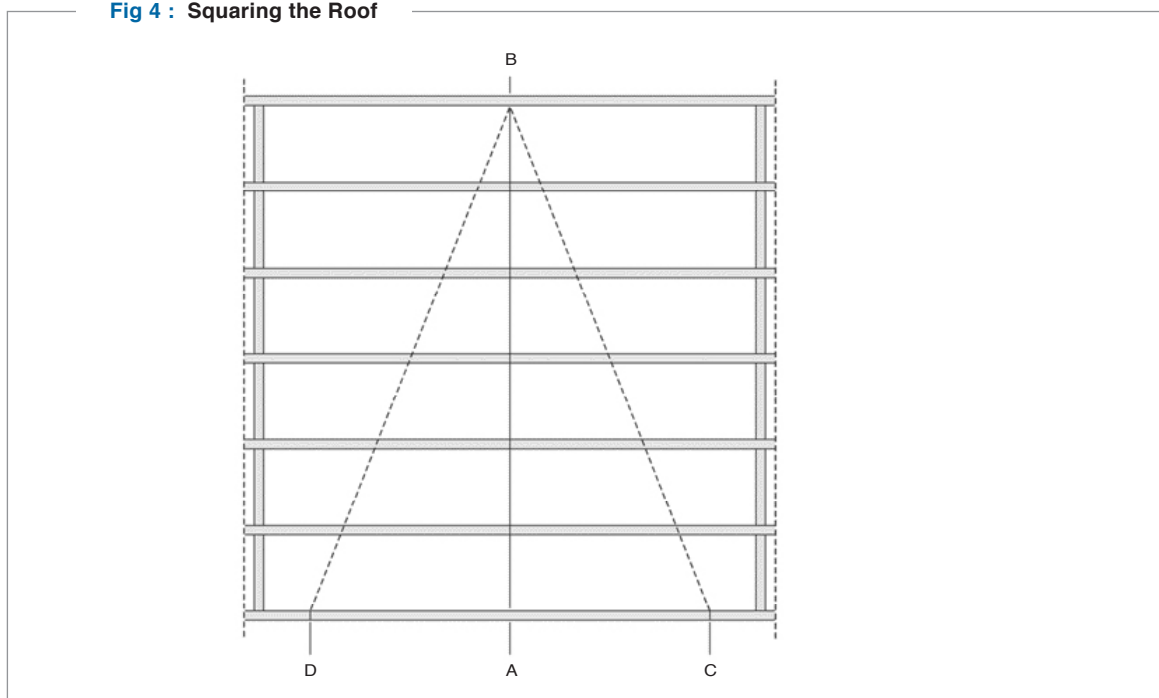

■ Step 5

Marking out the Battens for Slating *Refer Fig.5.*

Starting from the centre line, mark tilter batten on either side of the centre line at equal distances of 206 mm for the 610 x 406 slate, finishing with equal spacings at both gable ends of the roof slope. Repeat this procedure along the ridge batten.

Strike chalk lines from the tilter batten to the ridge batten to mark remaining battens.

Fig 5 : Marking the Battens for Slating

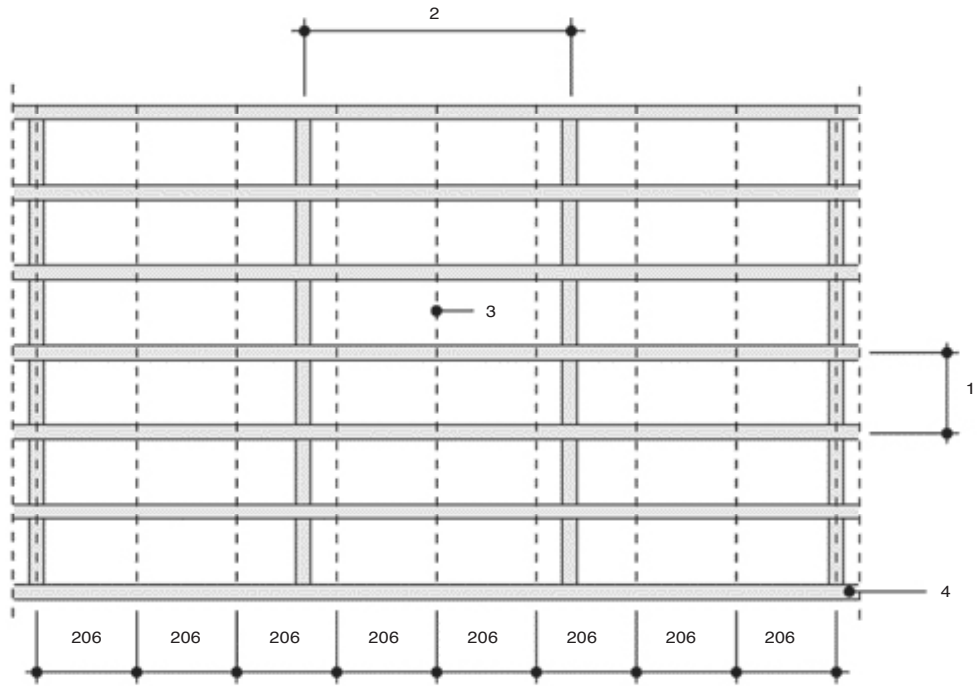

KEY	
1	Battens at 250 mm centres for 610 x 406 slate
2	Rafters
3	Centre line of roof slope
4	Tiler batten

All dimensions in mm.

INSTALLATION PROCEDURES

■ Step 6

Trimming of Battens *Refer Fig. 6*

From the last chalk line at the gable end, mark back on the triller batten the width of a batten plus the thickness of the barge board for the barge board option chosen.

Mark the ridge batten in the same way.

Strike a chalk line to mark the remaining battens.

Trim all battens on these marks.

Nail gable trimmer batten in position.

Fig 6 : Barge Board Options

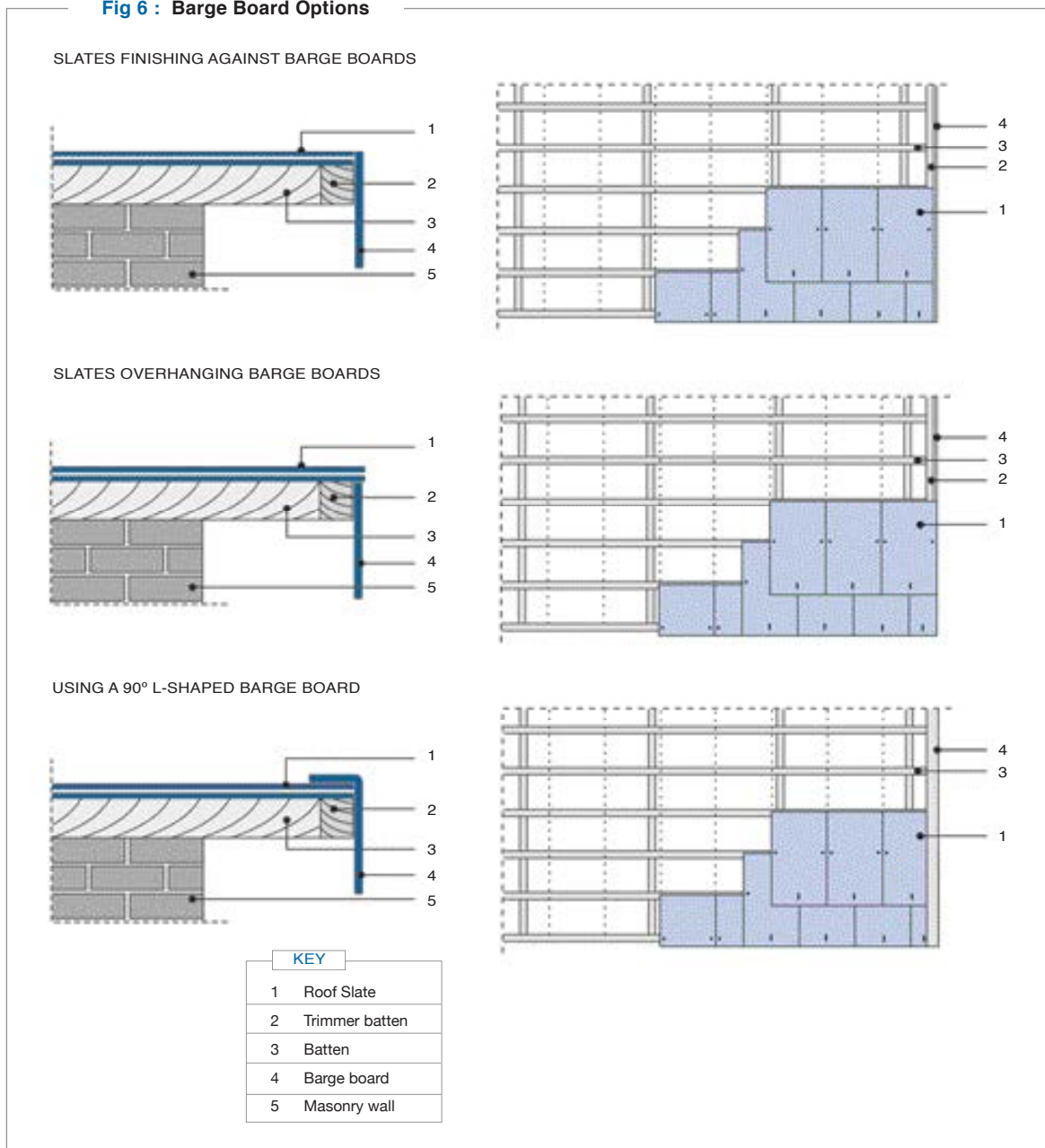

■ **Step 7**

Laying of Slates. *Refer Fig.8*

IMPORTANT GUIDELINES

- Copper nails should be used throughout in all corrosive areas, and also on all exposed areas, e.g. ridges and hips.
- Fixing holes. 610 mm x 406 mm slates are pre-drilled with 3 holes. The 2 holes on the side of the slate are for nailing the slate to the batten, while the third hole at the bottom centre is for the disc rivet. *Refer Fig. 7.*
The nails securing the slates must be driven firmly but not too hard as this will tilt the slate.
- The top of slates should not extend above the centre line of the battens, as this will interfere with the nailing of the next row of slates.
- Cut starter slates to size required. For cutting of slates *Refer Fig.1.* Retain offcuts for use at the ridge.
- The length of the starter slate is measured from the overhang into the gutter to the centre line of the second batten.

Starting at one end of the roof, fix starter slates between chalk lines with 40mm galvanised or copper clout nails, to tilter batten.

Ensure that the top of starter slate is not above the centre of the second batten.

For the next row cut a standard slate in half down its length. Fix the cut slate and drill the additional hole for the second fixing nail. Insert a copper disc rivet in position B. *Refer Fig. 8.*

Drill a second hole in this half slate through the starter slate in position A (centred on the slate and on the centre line of the tilter batten) and fix with a 50 mm clout nail.

Next to the cut slate use a full slate and fix with 40 mm clout nails. Insert a copper disc rivet under the leading edge in position D, before placing the next slate. Insert a copper disc rivet in position C between the two starter slates and through the hole provided in the full slate and bend it over. Continue in this manner until the second row has been completed.

For the third row, place a full slate in position over disc rivet B and nail to the third batten. Bend over the disc rivet and proceed with full slates according to chalk lines. Continue fixing full and cut slates to the ridge of the roof in accordance with previous instructions.

NB: The last slate at the ridge has to be cut to suit.

Refer Fig.9.

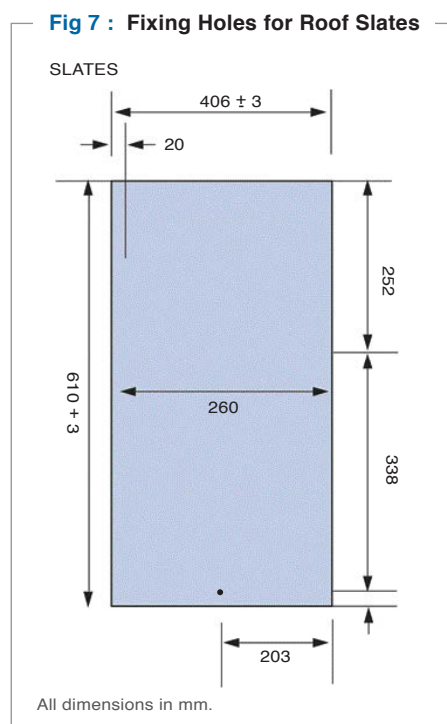

INSTALLATION PROCEDURES

Fig 8 : Laying of Slates

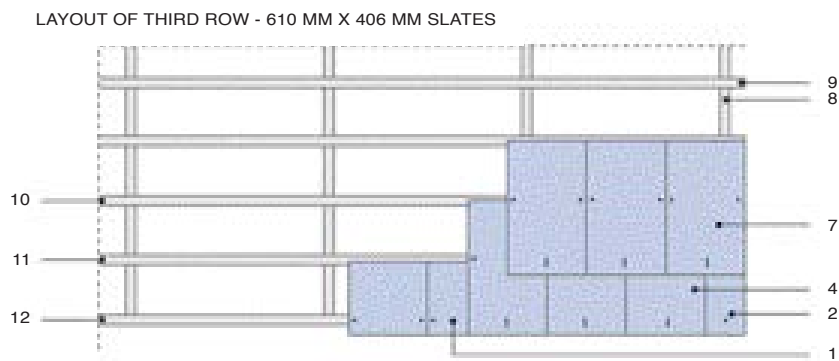
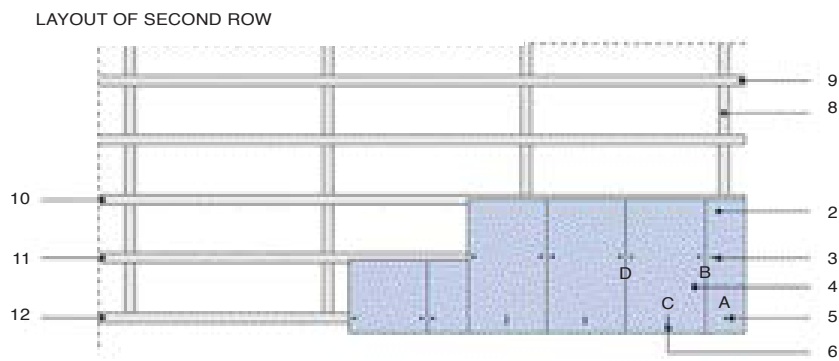
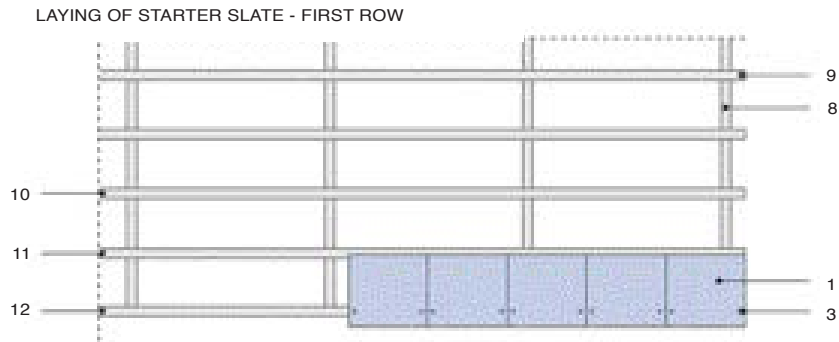

KEY

1	Starter slate
2	Cut slate 2nd row
3	Nailing position
4	Full slate 2nd row
5	50 mm Copper clout nail
6	Copper disc river
7	Full slate 3rd row
8	Rafters
9	Battens
10	3rd Batten
11	2nd Batten
12	Tilter batten

■ **Step 8**

Fixing the Ridge *Refer Fig.9.*

To obtain a straight ridge, lay slates to chalk line marking the position of the bottom edge of the ridge slates. Ensure that the centre ridge batten is fixed in position.

Cut under-ridge slates to suit, ensuring that these butt at the apex of the roof and that the overlap onto the previous row is the same as for the rest of the roof.

Cut and lay a continuous bitumen-impregnated soaker to fit under under-ridge slate (100 mm on both sides).

Nail under-ridge slates in position over bitumen-impregnated soaker.

Cut ridge slate to suit, allowing them to butt-joint at the apex.

Cut and fit continuous ridge soaker made up of one layer of bitumen-impregnated membrane and a layer of sisalation or aluminium foil, which is required to protect the membrane from UV deterioration.

In the case of mitred ridge, the offcut retained from the starter slate is cut to suit.

Drill and nail in position using 50 mm copper clout nails.

NB: For the Boston type ridge the offcut retained from the starter slate is cut to suit, half lapped, drilled and nailed using 50 mm copper clout nails.

Fig 9 : Ridge Options

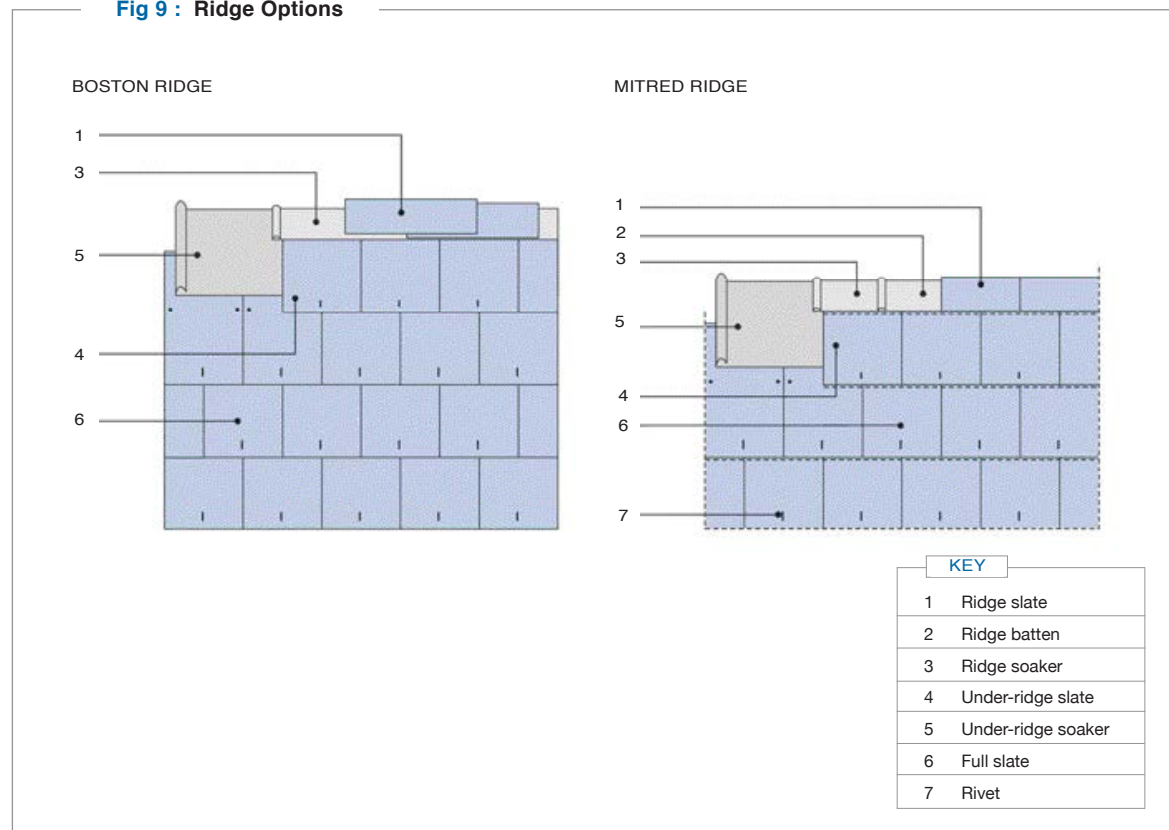

INSTALLATION PROCEDURES

Fig 9 (continued) : Ridge Options

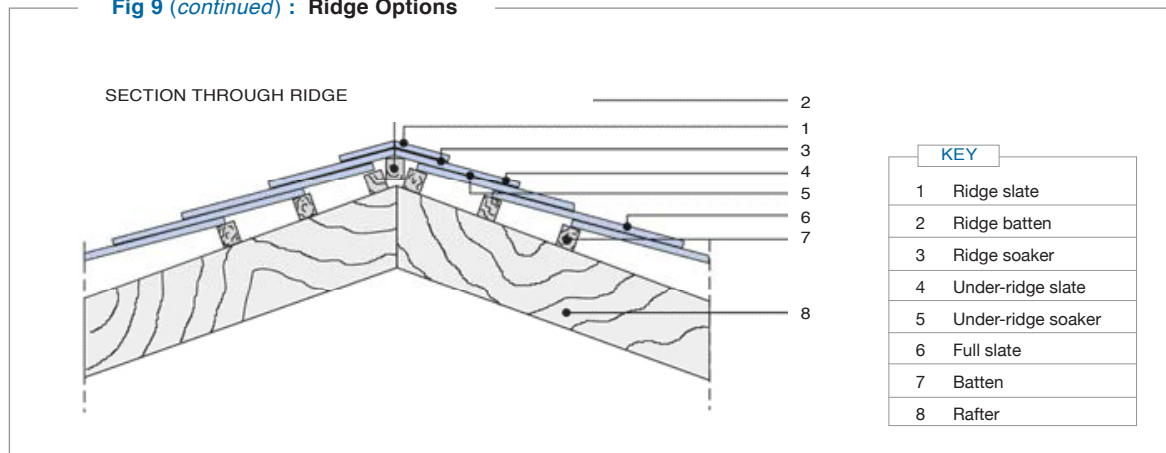

Valleys

There are two options for valley construction i.e. open valleys and closed valleys.

As a general rule, galvanised metal flashing will be used in inland areas while copper or lead is recommended for coastal or corrosive areas.

■ Step 9

Constructing an Open Valley *Refer Fig.10.*

Check that valley battens are positioned as close as possible to the channel of the valley flashing piece to provide for nailing of small cut slates where they occur.

Position the valley flashing. Sections to lap a minimum of 150 mm. Cut at gutter to suit.

Commence slating by fixing starter slates. Mitre and cut to fit valley.

Complete the slating along the same lines with full slates, cutting each slate adjoining the valley to fit.

Fig 10: Open Valley Details

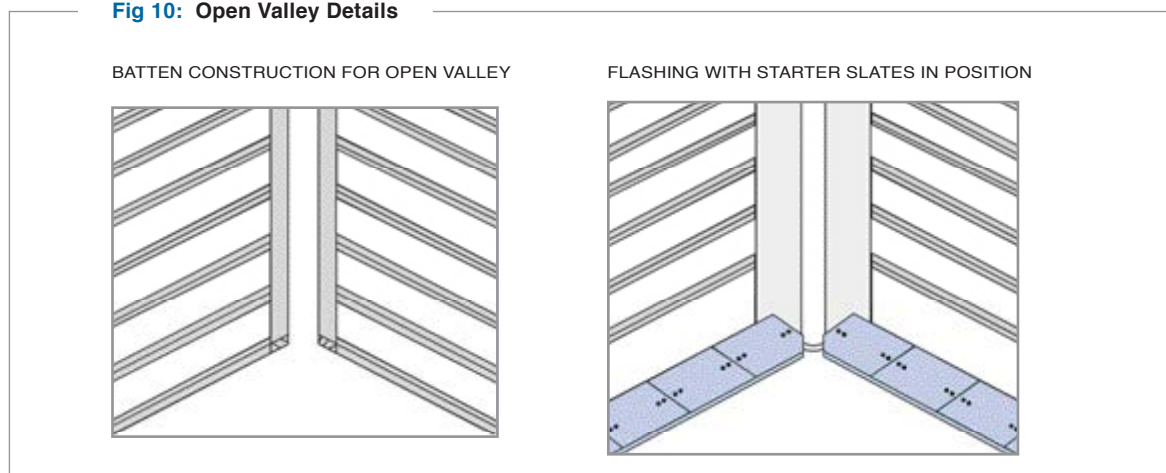
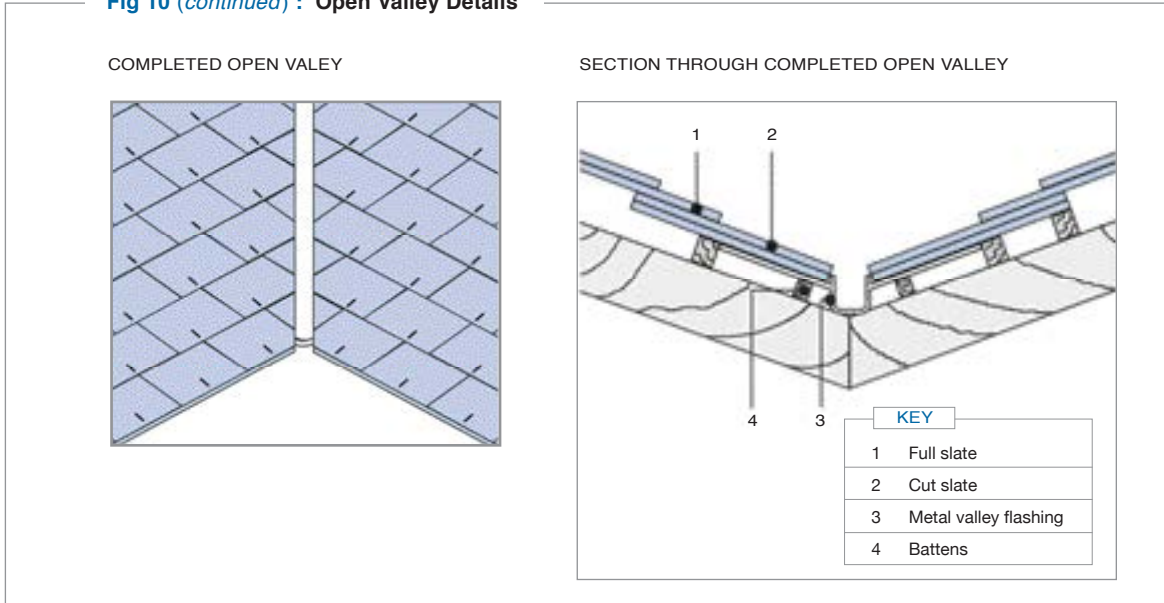

Fig 10 (continued) : Open Valley Details



■ **Step 10**

Construction of a Closed Valley Refer Fig. 11.

Ensure that battens are neatly mitred and aligned where they intersect on the valley rafter.

Place continuous metal valley flashing 450 mm wide in position. Sections must be lapped 150 mm minimum.

Mitre and fix starter slate in position.

Cut and position individual 450 mm wide bitumen-impregnated soakers.

Cut and fix first row of full slates in the valley.

Cut the second soaker and position with the lower edge just above the disc rivet for the subsequent row of slates.

Fig 11 : Closed Valley Details

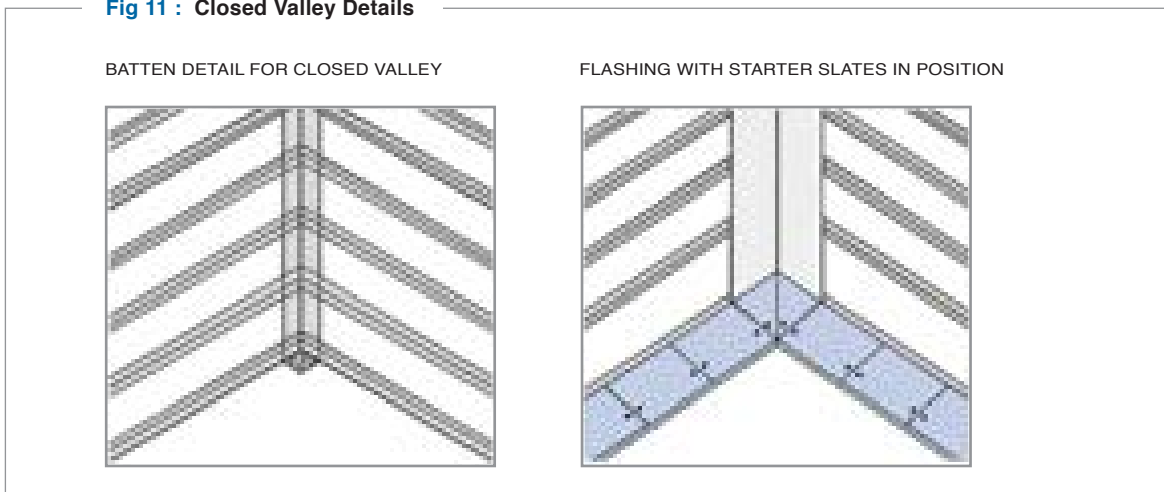

INSTALLATION PROCEDURES

Fig 11 (continued) : Closed Valley Details

POSITION OF INDIVIDUAL SOAKERS

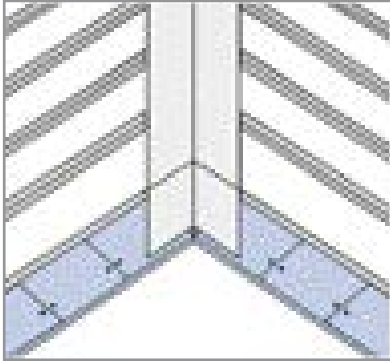

POSITIONING AND MITRING OF FULL SLATES

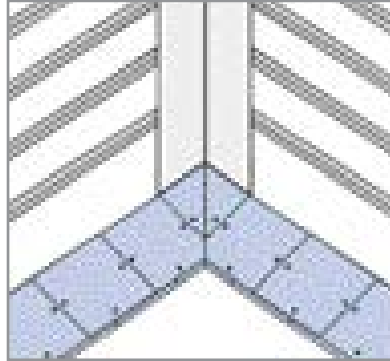

SECOND SOAKER IN POSITION

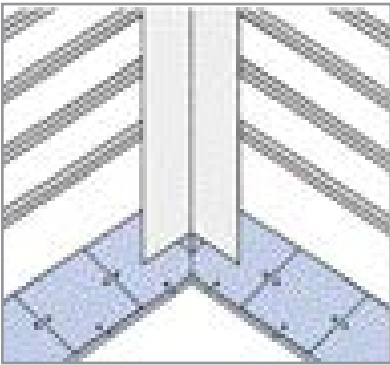

COMPLETED CLOSED VALLEY

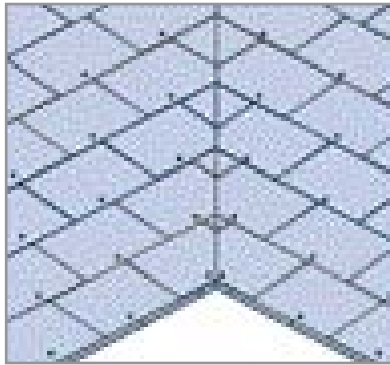

SECTION THROUGH COMPLETED CLOSED VALLEY

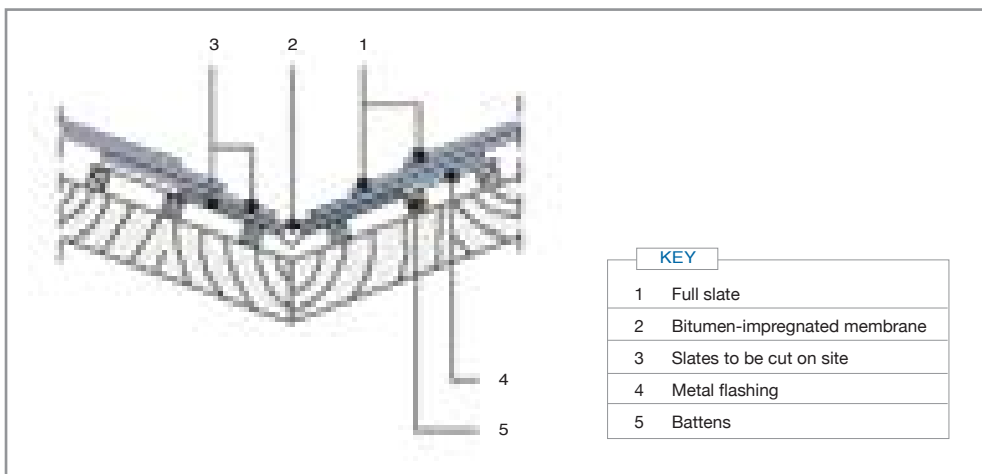

■ **Step 11**

Constructing a Raised Boston Hip *Refer Fig.12.*

Check that the battens fit neatly against the hip rafter. To raise the hip, nail a batten on top of the rafter.

Mitre cut and fix starter slate to meet at hip.

For the next row onwards repeat with full slates and mitre to suit.

Position a 380 mm wide continuous bitumen-impregnated soaker centrally over full length of hip.

Cut and fix Boston starter slates.

NB: Slates used for Boston hip are standard slates, halved longitudinally. They are fixed in such a way that the lower corners of the hip slates line up with the lower edge of normal roof slates, the upper end of the hip slate being cut.

Fig 12 : Details of Raised Boston Hip

BATTEN LAYOUT FOR BOSTON HIP

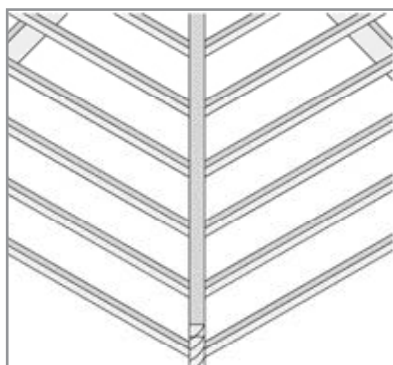

BOSTON HIP STARTER SLATES IN POSITION

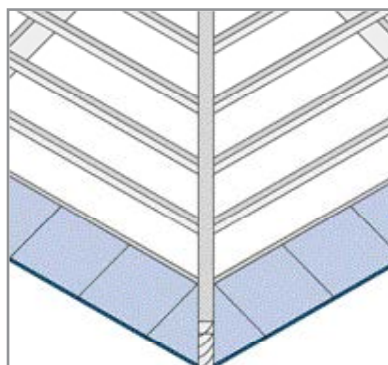

POSITIONING AND MITRING OF FULL SLATES

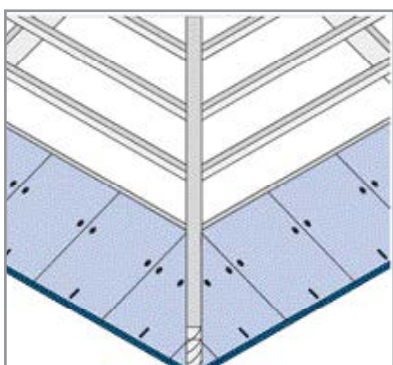

HIP READY FOR COVER SLATES

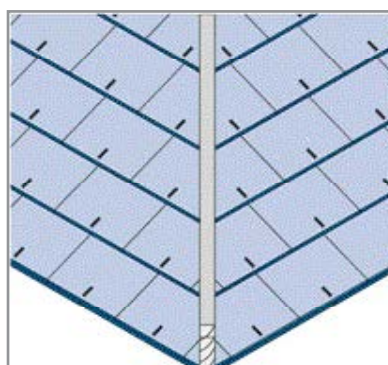

INSTALLATION PROCEDURES

Fig 12 (continued) : Details of Raised Boston Hip

CONTINUOUS SOAKER ON POSITION

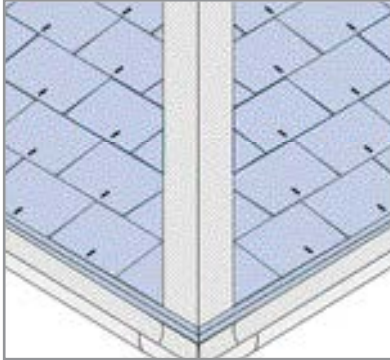

CUTTING AND FIXING OF THE HIP STARTER SLATE

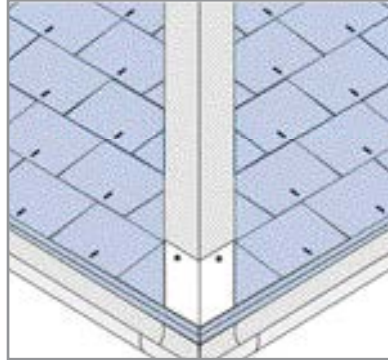

COMPLETED RAISED BOSTON HIP

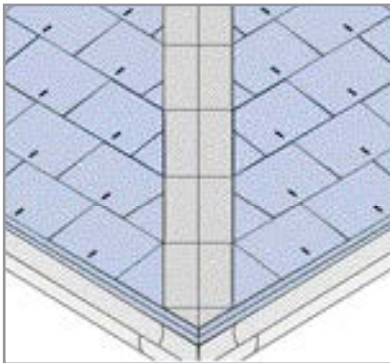

FIXING POSITIONS FOR THE BOSTON HIP

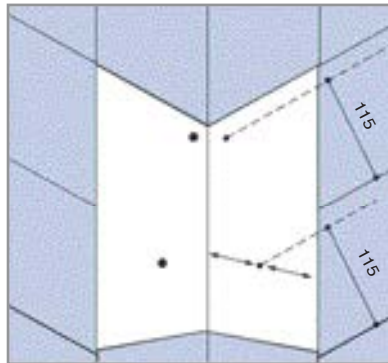

SECTION THROUGH RAISED BOSTON HIP

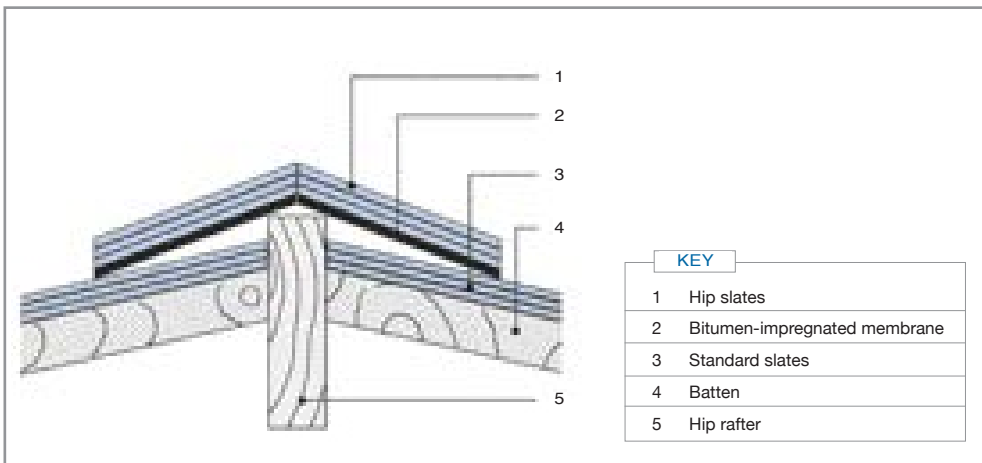

■ **Step 12**

Flashing around a Chimney *Refer Fig. 13.*

The standard procedure, which is commonly used, is quite satisfactory for normal pitch roofs.

Ensure that battens are properly finished off around the chimney so that the flashing and slates have a proper support.

Slate the lower side of the stack and where necessary trim the last full row of roofing slates around the chimney.

Fix metal apron flashing in position on the lower side of the chimney stack.

Nail the following row of roofing slates in position, covering the apron flashing and trim where necessary around the stack.

Place the first pair of metal soakers in position on the side of the stack. (For dimensions of apron soaker refer to '**Fixing Accessories**').

Fix the next row of slates to butt against the vertical leg of the flashing.

Install the next metal soaker and repeat this procedure.

Position the back flashing and continue with slating.

Complete slating and trim around upper end of stack over back flashing where required.

Fix counter flashing by wedging into raked out brick joints. The counter flashing should be evenly stepped on chimney sides.

Fig 13: Details of Chimney Flashing

BATTEN LAYOUT AROUND CHIMNEY

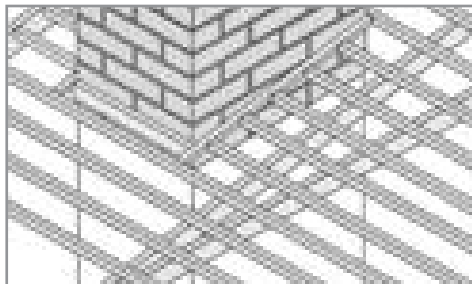

SLATING TO CHIMNEY

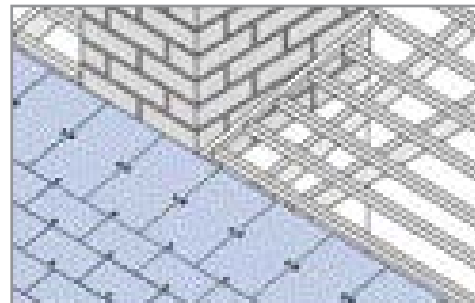

APRON FLASHING TO CHIMNEY

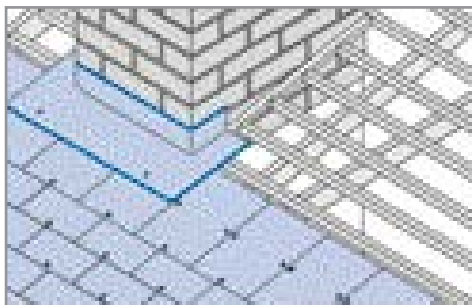

SLATING AROUND CHIMNEY

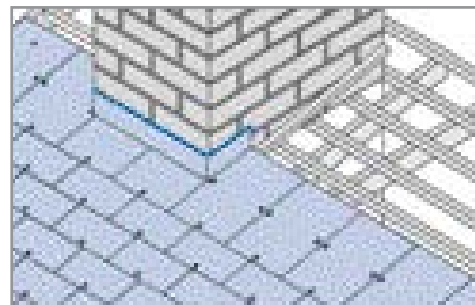

INSTALLATION PROCEDURES

Fig 13 (continued) : Details of Chimney Flashing

POSITIONING ODF INDIVIDUAL METAL SOAKERS

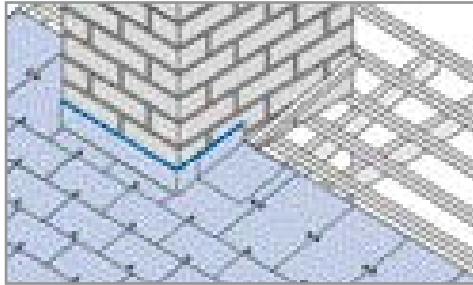

SLATING AROUND CHIMNEY CONTINUED

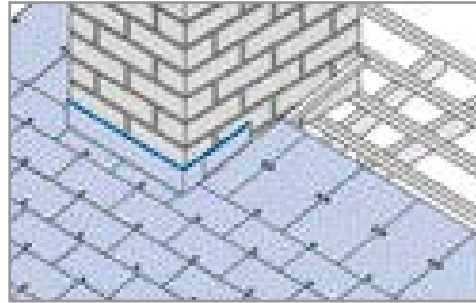

BACK FLASHING IN POSITION

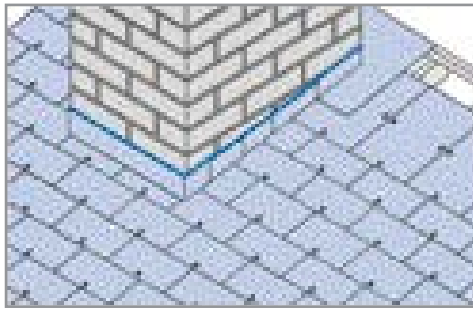

SLATING COMPLETED

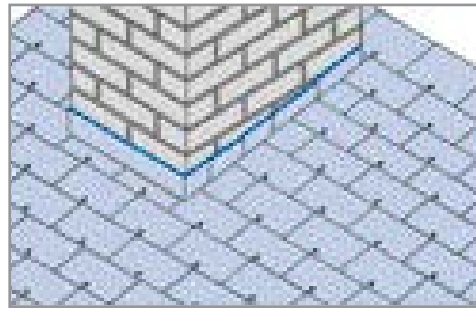

COUNTER FLASHING IN POSITION

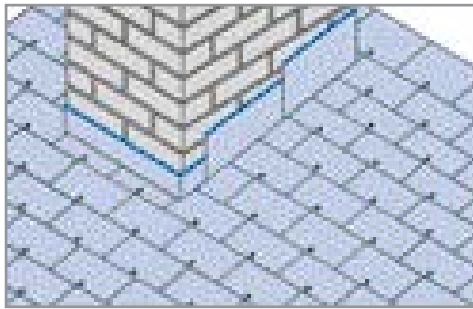

■ Step 13

Special Flashing Details Refer Fig. 14.

In certain instances, special flashing methods may be necessary and a few examples are detailed below.

Fig 14 : Fixing Details for Special Flashing Situations

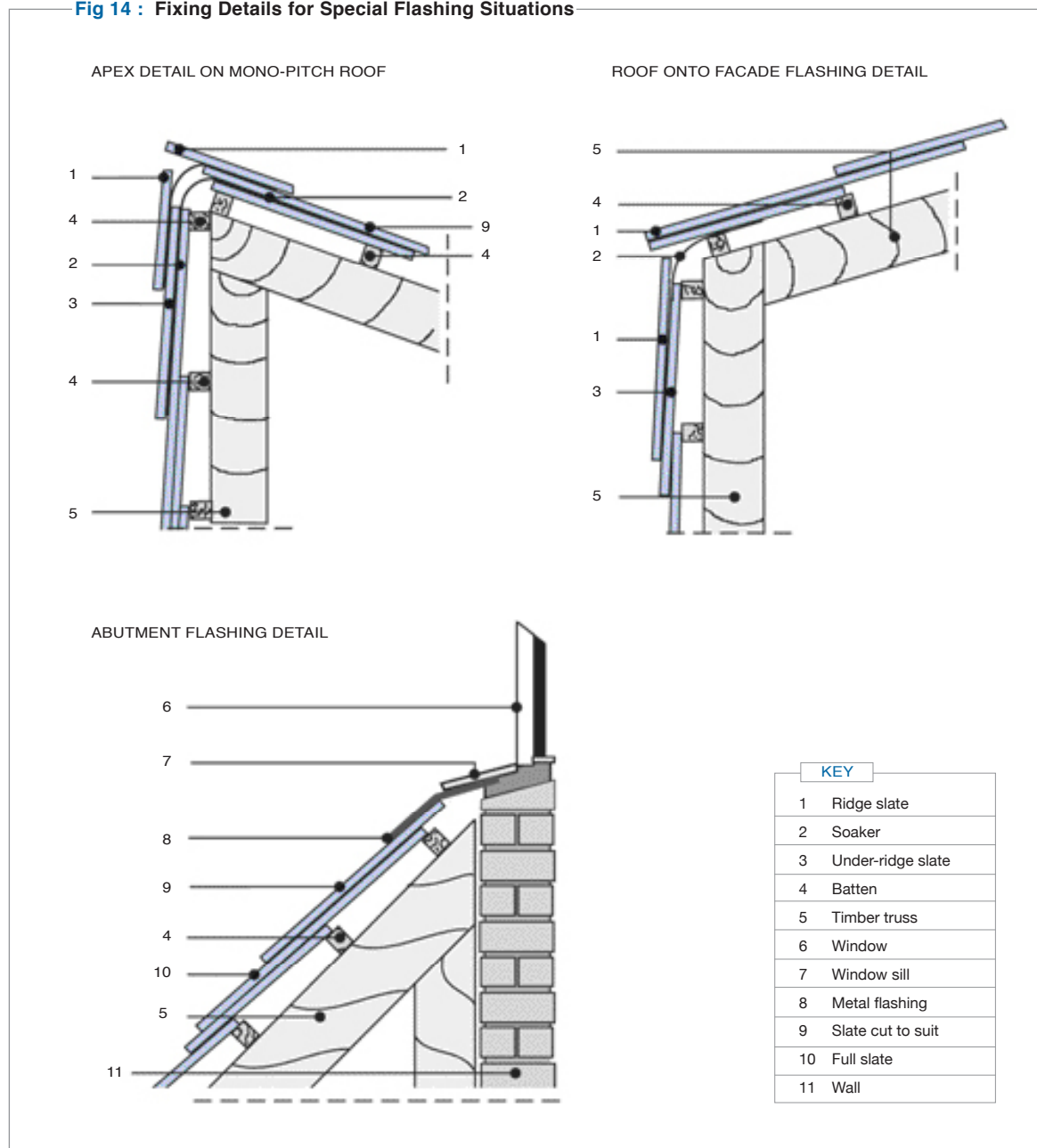

INSTALLATION PROCEDURES

■ Step 14

To replace a damaged roof slate Refer Fig. 15.

Open the copper disc rivet of the damaged slate.

Insert the slate ripper under the damaged slate.

Hook the slate ripper onto the first nail.

Withdraw the slate ripper by tapping it with a hammer.

Repeat for second nail.

Remove broken slate.

Hammer a nail halfway into the exposed batten in the centre of the opening.

Tie a length of copper wire to this nail.

Hammer the nail in until the head is flush with the slate.

Push the new slate into position.

Insert new copper disc rivet.

Tie the wire around the copper disc rivet.

Cut off the excessive wire.

Complete the replacement of the slate by bending the pin of the copper disc rivet over.

Fig 15 : Replacing a damaged Slate

REMOVING BROKEN SLATE

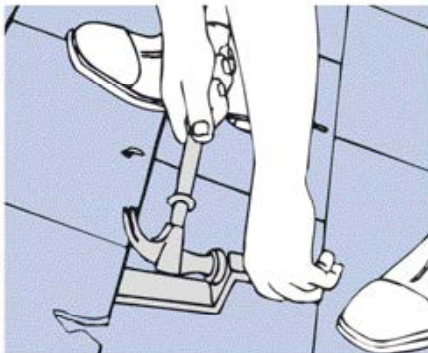

FIXING WIRE TIED TO NAIL

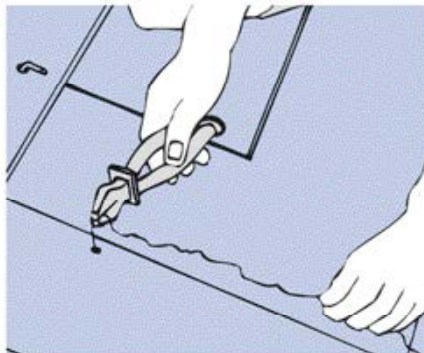

INSERTING REPLACEMENT SLATE



FASTENING REPLACEMENT SLATE

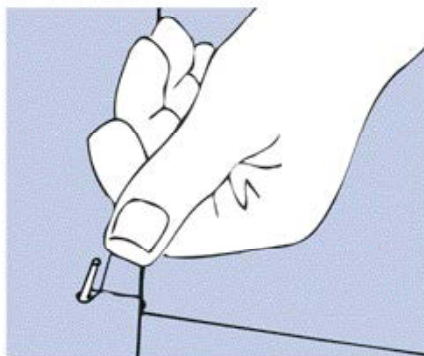

Nutec Slate Fixing Accessories

Product No.	Size / Description	Diameter mm	Sketch of Article
605-011	Copper Disc Rivets	30 x 20	
605-134	** Copper Clout Nails	50 x 2,5	

** All copper and galvanised clout nails have serrated shanks.

** Longer nails are used for hip and valley construction.

Estimating Quantities

There are various simple methods for extracting quantities for slate roofs and one such method is detailed below.

Information required to calculate quantities are:

- Dimensions of flat roof area (overall wall dimensions plus eaves and gable overhang).
- Roof pitch (either as detailed on the drawing or by measurement with a protractor).

Example

To calculate the flat roof area it is usually necessary to divide the roof into easy to calculate rectangular sections, *see Fig.16*.

NB: The whole roof area, including eaves and gable overhang must be included.

In the example the roof is divided into four convenient areas.

Area 1:	40,0 m x 10,0 m	=	400,0 m
Area 2:	10,0 m x 7,0 m	=	70,0 m
Area 3:	3,0 m x 4,0 m	=	12,0 m
Area 4:	10,0 m x 8,0 m	=	80,0 m
Total flat roof area		=	562,0 m ²

The developed roof area is obtained by dividing the flat roof areas by the cosine of the roof angle.

In the example the flat roof area was calculated as 562 m² and the roof pitch is given as 30°.

The cosine for 30° is 0,866. *Refer to Table 2*.

The developed roof area is therefore $563 \text{ m}^2 \div 0,866 = 648,961 \text{ m}^2$

NB: This method applies equally to roofs with gable ends and hips as well as mono-pitch roof areas.

- **Where different roof pitches are encountered on the same roof, the flat roof areas have to be calculated separately for each different roof pitch area.**

To obtain the number of roofing slates and fixing accessories required, multiply the developed roof area by the number of units per m. *Refer Estimating Roofing Quantities*.

NB: Allowance must be made for extras in the roofing slates and fixing accessories where ridges and hips are involved, as well as for cutting wastes.

- **50 mm copper clout nails must be used at all exposed fixing points, e.g. ridges and hips. These should be allowed for as per Table 3.**
- **Copper nails should be used throughout in all corrosive areas.**

Fig 16 : Extracting Quantities for Slate Roofs

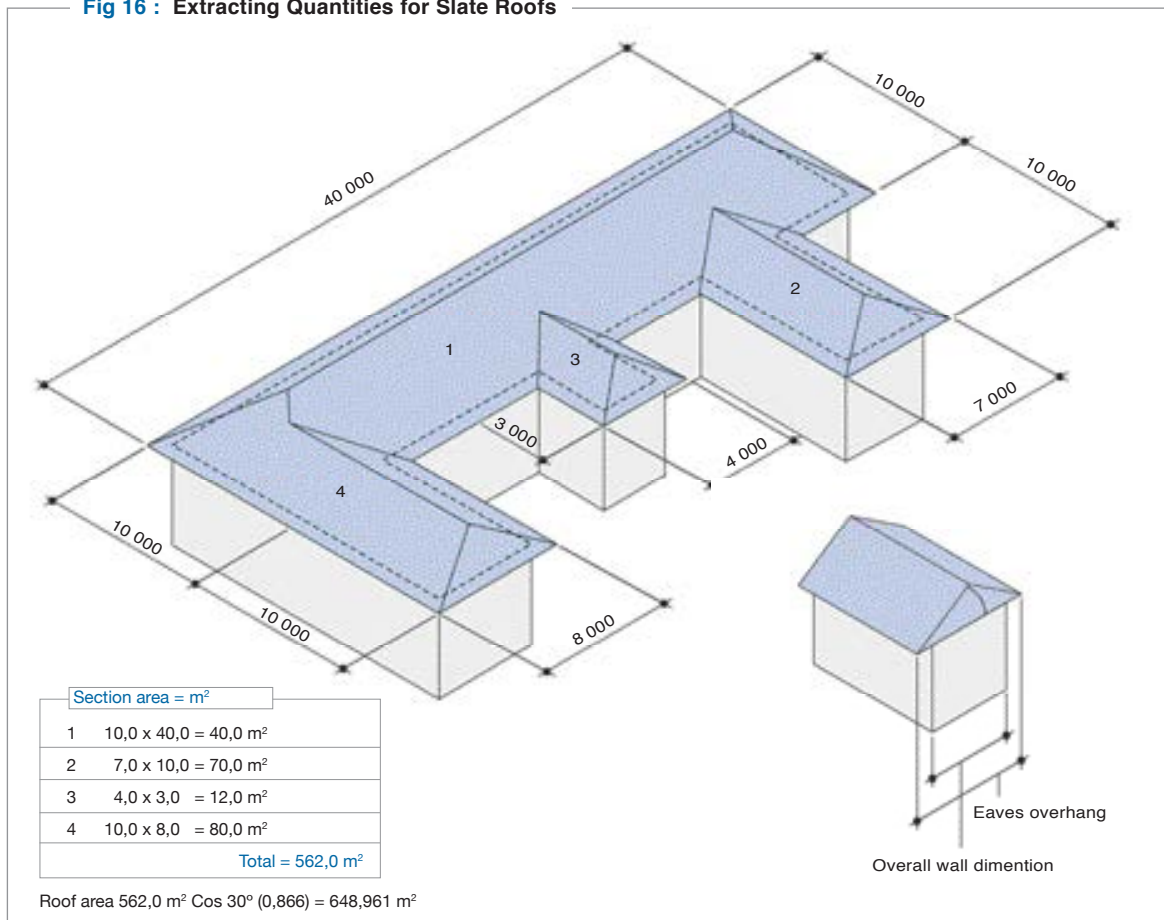

TABLE 2

Natural Cosines					
Roof Pitch	Cosine	Roof Pitch	Cosine	Roof Pitch	Cosine
16°	0,9613	31°	0,8572	46°	0,6947
17°	0,9563	32°	0,8480	47°	0,6820
18°	0,9563	33°	0,8387	48°	0,6691
19°	0,9455	34°	0,8290	49°	0,6561
20°	0,9397	35°	0,8192	50°	0,6428
21°	0,9336	36°	0,8090	51°	0,6293
22°	0,9272	37°	0,7986	52°	0,6157
23°	0,9205	38°	0,7880	53°	0,6018
24°	0,9135	39°	0,7771	54°	0,5878
25°	0,9063	40°	0,7660	55°	0,5736
26°	0,8988	41°	0,7547	56°	0,5592
27°	0,8910	42°	0,7431	57°	0,5446
28°	0,8829	43°	0,7314	58°	0,5299
29°	0,8746	44°	0,7193	59°	0,5150
30°	0,8660	45°	0,7071	60°	0,5000

ESTIMATING QUANTITIES

TABLE 3

Slate Fixing Accessories - Numbers Required			
Application and Product Description	Units	Slate sizes 160 x 406	
Roof area			
■ Roof slates	Number per m ²	10	
■ 50mm galvanised/copper clout nails	Number per m ²	20	
■ Copper disc rivets	Number per m ²	10	
Eaves Starter Slate			
■ Roof slates	Number per lin. m	2.5	
■ 50mm galvanised/copper clout nails	Number per lin. m	5.0	
■ Copper disc rivets	Number per lin. m	2.5	
Mitred ridge			
■ Roof slates	Number per lin. m	10	
■ 50mm copper clout nails	Number per lin. m	20	
■ Copper disc rivets	Number per lin. m	-	
Boston ridges and hips			
■ Roof slates	Number per lin. m	10	
■ 50mm copper clout nails	Number per lin. m	20	
Valleys			
■ Included in cutting wastes		-	
Cutting wastes			
■ 3%-5% of base quantity.	To be calculated		

Estimating Roofing Slate Quantities

The following guide can be used for estimating quantities of EVERITE Nutec roof slates and fixing accessories required.

a) Calculating the flat roof area. Refer Fig. 16.

Area 1: m x m = m² Area 2: m x m = m²
 Area 3: m x m = m² Area 4: m x m = m²
 Area 5: m x m = m² Area 6: m x m = m²
 Total roof area : m²

- Where textured slates (7 mm) are used, fixing accessories will differ slightly, ie: 40 mm galvanised nail becomes 50 mm on main roof area, on hips and ridges 50 mm copper nail becomes 63 mm.

b) Calculating developed (actual) roof area.

Roof pitch _____ °
 Cosine _____ Refer Table 2.
 Flat roof area _____ m²
 ÷ cosine of roof pitch _____ Developed roof area _____ m²

c) Calculating material quantities.

1. Roof slates

Slate size to be used _____ mm x _____ mm
 Developed roof area _____ m²
 x Number of slates per m² Number of slates: _____

2. Extras required

Eaves lin. m _____ Number of slates: _____
 x Number of slates per lin. m
 Ridges mitred lin. m _____ Number of slates: _____
 x Number of slates per lin. m
 Boston type ridges and hips lin. m _____ Number of slates: _____
 x Number of slates per lin. m
 Hips mitred lin. m _____ Number of slates: _____
 x Number of slates per lin. m
 Cutting waste 3%-5% of base quantity
 depending on the complexity of the roof _____ %= Number of slates: _____

d) Fixing accessories

1. 40mm galvanised/copper clout nails

Galvanised _____ per kg. Copper _____ per kg.
NB: Copper clout nails are recommended for corrosive areas such as coastal areas.
 Number of slates: _____
 x 2 _____
 ÷ Number per kg _____

2. Disc rivets – 1 per slate Each : _____

3. 50mm copper clout nails

NB: To be used at all exposed fixing points – ridges and hips
 Mitred ridge/hip lin. m _____
 x Number per lin. m _____ Each : _____
 ÷ Number per kg
 Boston ridge/hip lin. m _____
 x Number per lin. m _____ Each : _____
 ÷ Number per kg

CONTACT DETAILS

EVERITE NATIONAL OFFICE

Call Centre + 27 11 439 4400
www.everite.co.za



OTHER REGIONS

Sales Support Office

Telephone + 27 11 439 4400

Bloemfontein

Mobile 083 798 8049

Cape Town

Telephone + 27 21 981 5212

Durban

Telephone + 27 31 701 0959

East London

Mobile + 27 79 516 6510

George

Telephone + 27 44 873 2408

Mobile + 27 83 286 3435

Middelburg (Mpumalanga)

Mobile + 27 83 778 2787

Polokwane

Telephone + 27 15 297 3559

+ 27 15 297 3560/1

Port Elizabeth

Telephone + 27 41 451 0655

Mobile + 27 83 780 6162

Worcester

Telephone + 27 21 981 5212

Mobile + 27 83 286 3429

Botswana (Gaborone)

Telephone + 27 11 439 4400

Namibia

Mobile + 264 81 124 2655





www.everite.co.za
call centre: 0861 333 835



Copyright © 2012
Everite Building Products (Pty) Ltd.
All rights reserved.