

lasting strength
with fibre-cement

nutec
ROOFING AND CLADDING SOLUTIONS

Manufactured by
EVERITE
Established in 1941

TONGUE & GROOVE

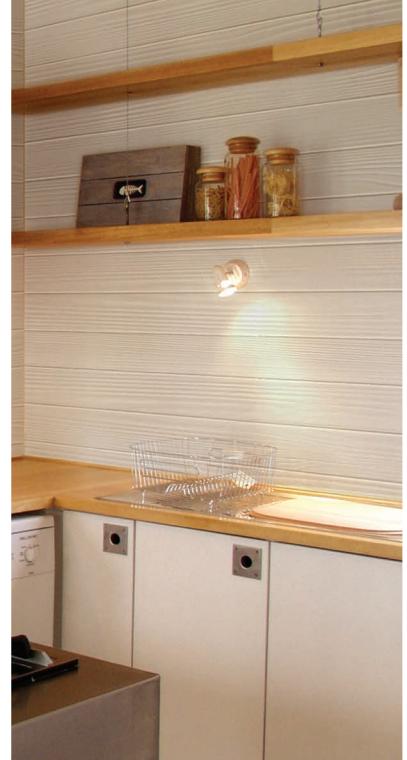

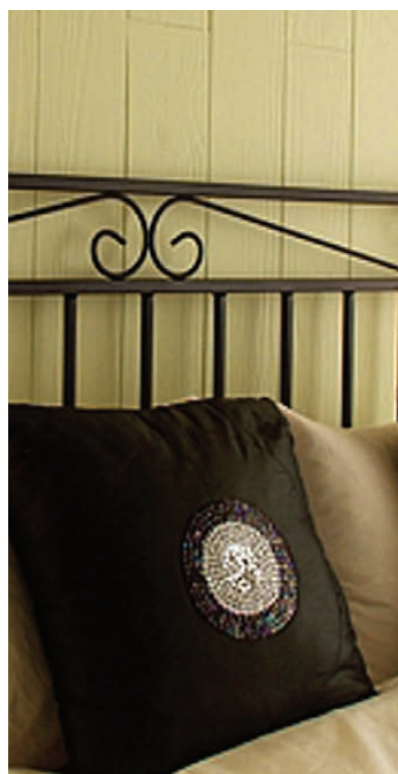
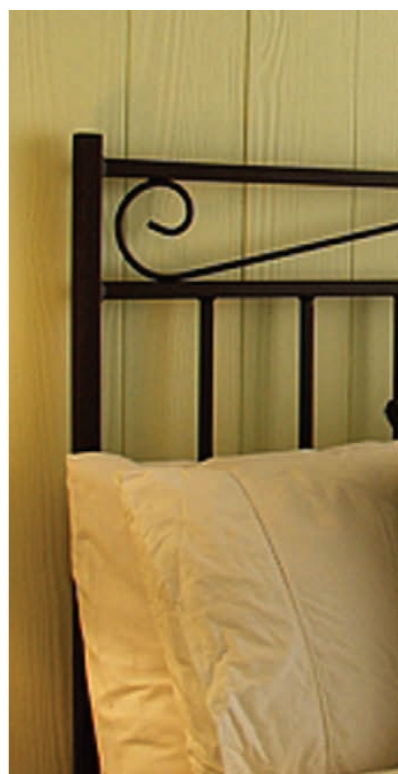

CONTENTS

| | |
|---|-----------|
| About Everite and Nutec | 2 |
| Nutec Flat Sheets Features | 4 |
| Safety, Handling and Storage | 5 |
| General Design Criteria | 6 |
| Nutec Flat Sheet Product Range | 8 |
| Application Possibilities | 9 |
| General Installation Guidelines | 10 |
| Guidelines and Fixing Details | 11 |
| Tongue and Groove Installation | 14 |
| Fire Resistance Systems | 18 |
| Acoustical and Thermal Values | 22 |
| Mechanical and Physical Properties | 24 |
| Everite National Offices and Contact Details | 30 |

Catalogue Information

The information contained in this catalogue serves as a general guide only and should not be accepted as the standard for all construction. EVERITE can assist in designs of a special nature, however, architects, engineers and specifiers must finally approve the acceptability in terms of the design and construction criteria, as well as other implications.

About Everite and Nutec

■ Everite Building Products

Everite Building Products, has been associated with the South African building industry since 1941. Producing a wide range of materials that satisfy the needs of the commercial, industrial and residential market sectors, Everite is renowned for its comprehensive range of Nutec Roofing and Cladding Solutions and includes fibre-cement roofing, cladding, ceilings and building columns amongst others.

Nutec fibre-cement high performance properties and added benefits include: the use of safe renewable fibres; considerable tensile strength with enhanced dynamic load bearing properties; excellent thermal properties; water and wind resistance; hail resistance; fire resistance and resistance to fungus, rodents and acid.

A programme of quality assurance in accordance with the requirements of the International Standards Organisation (ISO 9001:2015) is entrenched in Everite's process and management systems. Quality of all products is continuously monitored as specified by the South African National Standards and recognised international bodies.

Everite's 54 hectare manufacturing facility near Johannesburg is well located and has immediate access to all major road and rail links to national destinations and major ports. The company has branches located at major centres throughout South Africa. Nutec products are distributed through leading stockists countrywide and an established export market further endorses the international acceptance of the Nutec Roofing and Cladding Solutions range of products.

■ Nutec

Nutec is the registered name for products manufactured without asbestos as a raw material. Nutec fibre cement products are manufactured using a mixture of cellulose fibre, cement, silica and water.

Through ongoing research and development, Everite Building Products are committed to provide product of world-class quality.

Accordingly, the Nutec product range is continuously reviewed not only in the interests of the end-user and superior product performance, but also with respect to its impact on the environment. Everite Building Products has over the years established a reputation for producing a variety of outstanding quality products which have been used in a wide range of external and internal applications.

Environmental benefits of Nutec Fibre Cement

- Environmental costs incurred by using fibre cement are measurably less than for other building materials. (Low embodied energy per m²).
- Requires less energy in assembly and construction than all other wall materials except timber.
- Low energy consumption in transportation and installation.
- Environmental costs relating to ozone layer depletion, carcinogenic substances and solid waste emissions are almost negligible.
- Low environmental impact in relation to ozone layer depletion, carcinogenic substances, and solid waste emissions.
- No pesticides are involved in the manufacture or use of fibre cement.

The benefits of Nutec Fibre Cement

- The use of safe fibres.
- Considerable tensile strength with enhanced dynamic load bearing properties.
- Cost competitive.
- Excellent thermal properties.
- Water tight and wind resistant.
- Hail resistant.
- Fire-resistant.
- Fungus and rodent resistant.
- Acid resistant.
- Complies with SABS ISO 9933.
- ISO 9001 : 2015 Quality Management System.

The environmental benefits in the manufacturing process of Nutec Fibre Cement

- Recycling the water used in production many times.
- Recycling solid wastes.
- Using sustainable raw materials in production.

Embodied Energy – Definition

Embodied energy is the energy consumed by all of the processes associated with the production of a building, from the mining and processing of natural resources to manufacturing, transport and product delivery. Embodied energy does not include the operation and disposal of the building material. This would be considered in a life cycle approach. Embodied energy is the 'upstream' or 'front-end' component of the lifecycle impact of a home. Fibre cement is one of the most energy efficient materials on the market and it has one of the lowest embodied energy contents per square metre of cover of any building product.

NUTEC FLAT SHEETS FEATURES

Nutec Flat Sheets

Nutec Flat Sheets are an economical, multi-purpose building board that can be used in diverse exterior and interior applications, ranging from cladding, eaves linings and fascias to ceilings, partitioning, panelling and suspended flooring.

Nutec High-Density and Medium Density flat sheets provide considerable scope for design flexibility and creative expression. Used as a flat vertical surface, Nutec Flat Sheets are produced in a smooth or textured finish. They are supplied in a neutral colour that can accept a wide variety of coatings and paints to suit the palette of any application.

The range includes Nutec Tongue & Groove that is available in a plain or realistic wood grain finish and is suitable for use in a variety of applications, both interior and exterior. Supplied in a natural colour and, as it is compatible with a variety of paints, the timber-like finish can be enhanced with wood stain varnishes or paint techniques.

■ Features

- An economical all-purpose building board which is unaffected by moisture and therefore ideal for internal and external use in almost any application.
- Relatively light in weight and can be supported on light gauge metal frames or light timber structures. These factors facilitate easy handling and erection and are major benefits on projects where low mass construction is an important factor.
- Non combustible and provide perfect protection against flying sparks.
- Resistant to corrosion and are unaffected by ultraviolet light.
- Designed to have good thermal properties when compared with other building materials. The thermal properties of Nutec Flat Sheets compare very well with other building materials available on the market.
For thermal conductivity values (K value), .
- Manufactured to the highest internal quality standards and compliance is ensured by strict quality assurance programmes in the production process as well as stringent testing in our laboratory. Nutec Flat Sheets are manufactured to the requirements of ISO 9001:2015.
- All Nutec Flat Sheets carry a SABS mark for compliance to the specification SANS 803.
- Nutec Flat Sheets are supplied in their natural colour, but are compatible with a large variety of in-situ applied coatings and paints. This will allow the designer an almost limitless combination of colours and textures for external and internal applications.

Safety, Handling and Storage Instructions

Safety

Safety rules as per current legislation and work practices as described in General Installation Guidelines must be observed when working with the product.

Nutec Flat Sheets as manufactured are made without asbestos fibres, it is nevertheless recommended that when working with the product, tools that create excessive dust should not be used. Ordinary carpenters' tools can be used effectively.

Handling

Nutec Flat Sheets are cement-based and may be damaged under excessively high shock loads. Reasonable care should therefore be taken to ensure that the products are not dropped or subjected to rough handling.

Storage

Nutec Flat Sheets should not be exposed to the elements and under cover storage is recommended. A smooth level under cover area should therefore be made available where they can be stacked safely. Nutec Flat Sheets should be stacked clear off the ground on suitable timber supports at maximum 400 mm centres and the edges and corners protected against possible damage.

Where under cover storage is not available, the stacked product should be covered to avoid it becoming soaked with water. Soaked boards will be difficult to handle and should be allowed to dry out before use.

GENERAL DESIGN CRITERIA

General Design Criteria

Recommended Uses

The recommended uses of Nutec Flat Sheets under normal conditions are tabulated for easy reference in

Mechanical and Physical Properties

Details on the mechanical and physical properties of Nutec Flat Sheets are scheduled at the end of this brochure.

Painting, Finishes and Coatings

The sheets are best painted with a pure acrylic PVA paint. Where it is intended to use oil or alkyd paints it is essential to prime the sheet with an alkali-resistant sealer. In this instance both faces of the product should be sealed.

Exposed and Windy Conditions

The information presented in this catalogue is a guide only for normal wind-loading conditions.

Please consult an Engineer or Architect for advice on specific fixing and framing recommendations for structures in normal-or high-wind areas.

Substructure Guidelines

The design of structural supports requires professional expertise and should be executed by structural engineers.

TABLE 1

| Guideline - Supporting Structure for Nutec Flat Sheets | | |
|---|--|--|
| | External and Internal Vertical Cladding | |
| Description and Thickness of Board | Maximum spans between vertical supports | Maximum spans between horizontal supports |
| Medium density 9 mm 12 mm | 600 mm 800 mm | 600 mm 900 mm |
| High density 10 mm 15 mm | 600 mm 800 mm | 800 mm 1 200 mm |

- For specific fixing and framing recommendations where the sheets are to be used for applications such as floors, shelving and permanent shuttering, please consult an engineer or architect for details.
- If used for flooring, and covered with ceramic tiles or other inflexible material, expansion joints must be provided. Please refer to an engineer for details.

GENERAL DESIGN CRITERIA

Ventilation

When using Nutec Flat Sheets to form a double skin wall in a prefabricated steel or timber framed structure, the cavity (if not fully filled) between the two skins should be ventilated. In these structures, especially in humid conditions, foil is often installed as a moisture barrier and as an insulator. Ventilating the cavity will permit the evaporation of any condensation which may collect.

Site Service

Site service personnel are available on request to assist with recommended storage, handling and erection of the Company's products before and during installation.

NUTEC TONGUE AND GROOVE PRODUCT RANGE

Product Range

■ Nutec Tongue & Groove Product Range, Dimensions and Properties

Nutec Textured Tongue & Groove Medium Density (MD) Boards

| Product No. | Nominal thickness mm | Size mm | Average Mass per unit (kg) |
|-------------|----------------------|---------------|----------------------------|
| 650-567 | 6 MD | 1 200 x 2 400 | 24 |
| 650-568 | 6 MD | 1 200 x 3 000 | 30 |
| 650-569 | 6 MD | 1 200 x 3 600 | 37 |
| 060-643 | 9 MD | 1 200 x 2 400 | 35 |
| 060-644 | 9 MD | 1 200 x 3 000 | 44 |
| 060-645 | 9 MD | 1 200 x 3 600 | 52 |

Nutec Plain Tongue & Groove Medium Density (MD) Boards

| | | | |
|---------|------|---------------|----|
| 650-566 | 6 MD | 1 200 x 3 000 | 30 |
|---------|------|---------------|----|

Nutec Floor Boards High Density (HD) Boards

| | | | |
|---------|------|---------------|----|
| 011-504 | 15HD | 1 800 x 1 200 | 52 |
|---------|------|---------------|----|



Nutec Textured Tongue and Groove



Nutec Plain Tongue and Groove

APPLICATION POSSIBILITIES

TABLE 2

| Recommended Uses of Nutec Flat Sheets | | | | | | | |
|---|----------------|-------------|---------------|---------------|--------------|-------------|--|
| Product Description | Medium Density | | | | High Density | | |
| | 9 mm Plain | 12 mm Plain | 6 mm Textured | 9 mm Textured | 10 mm Plain | 15 mm Plain | |
| Internal panelling | • | • | • | • | | | |
| Gable cladding | • | • | | • | • | | |
| Prefabricated housing | • | • | | • | • | | |
| Steel & Timber frame houses & steel frame interior / exterior walls | • | • | | • | • | • | |
| Partitioning | • | | | • | • | | |
| Sandwich panels (Double skin light weight steel infill) | • | | | | | | |
| Louvres | | • | | | • | • | |
| Balustrading | | | | | • | • | |
| Steel beam and column lining (Aesthetic finish) | • | • | | | • | • | |
| Permanent shuttering | | | | | | • | |
| Toilet and shower partitioning | | | | | • | • | |
| Floors | | | | | | • | |
| External facades (stone chip finish) | • | • | | | • | | |
| External facades (paint application) | • | • | | • | • | | |
| Suspended floors | | | | | | • | |

GENERAL INSTALLATION GUIDELINES

General Installation Guidelines

- To ensure a high standard of finish, it is essential that the supporting structure is accurately constructed. Warped, twisted or poor quality timber, or badly erected steelwork will reflect in the finished surface and can cause damage to the product.

The structure must be checked and adjusted as necessary to ensure that there is no bowing or distortion which could affect the true plane of the final application.

- For maximum spacings between supports for Nutec flat sheets, refer and for guidelines.

Sheets should not be fixed directly onto a masonry wall, but on timber or steel battens forming a framework to which the fascia boards or sheets can be fixed.

- Holes for fixing must be set out evenly and must be drilled and not punched.

An ordinary hand drill and steel drill bits specially sharpened to a 20° angle are recommended.

The drill bit must be 2 mm larger than the diameter of the fixing bolt or screw.

- When the sheets are fixed into a framed structure allowance must be made for thermal movements in the sheet and the supporting structure.

The allowance for movement will depend on the size of the sheet, but an average can be accepted as ± 2 mm per metre in both directions. For facade jointing, use recommended jointing details.

Installation Guidelines and Fixing Details

■ Special Fascia Boards

Fig 1 : Using Nutec Flat Sheets as a Special Fascia

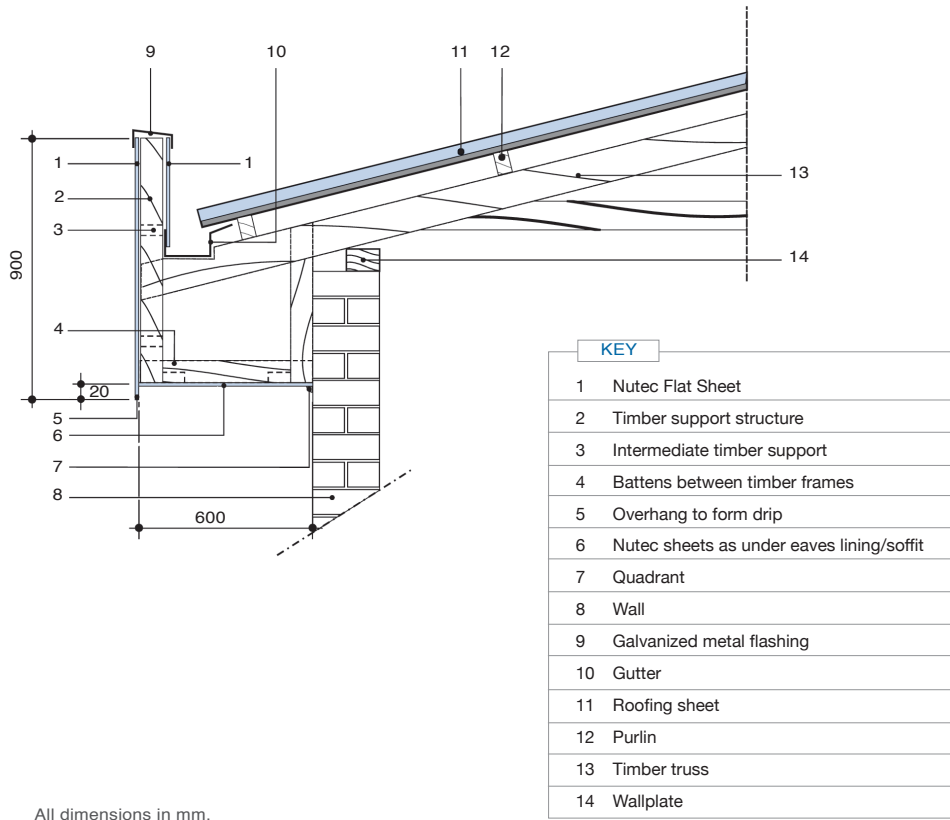

NB:

- In the above application 9 mm medium density sheets are used. In instances where ceramic tiles are fixed to a fascia, minimum thickness of sheets should be 10 mm high density or 12 mm medium density sheets.
- The flashing should be sloped away from the face of the fascia to avoid discolouration due to dust being washed down by rain over the finished surface.
- Guideline for spanning capabilities of NUTEC FLAT SHEETS, [Refer Table 1.](#)
- Fascias should not be fixed directly to a wall, use timber battens to provide a framework for the fascia.

INSTALLATION GUIDELINES AND FIXING DETAILS

■ Typical Layout of Nutec Flat Sheet on Timber and Steel Framework

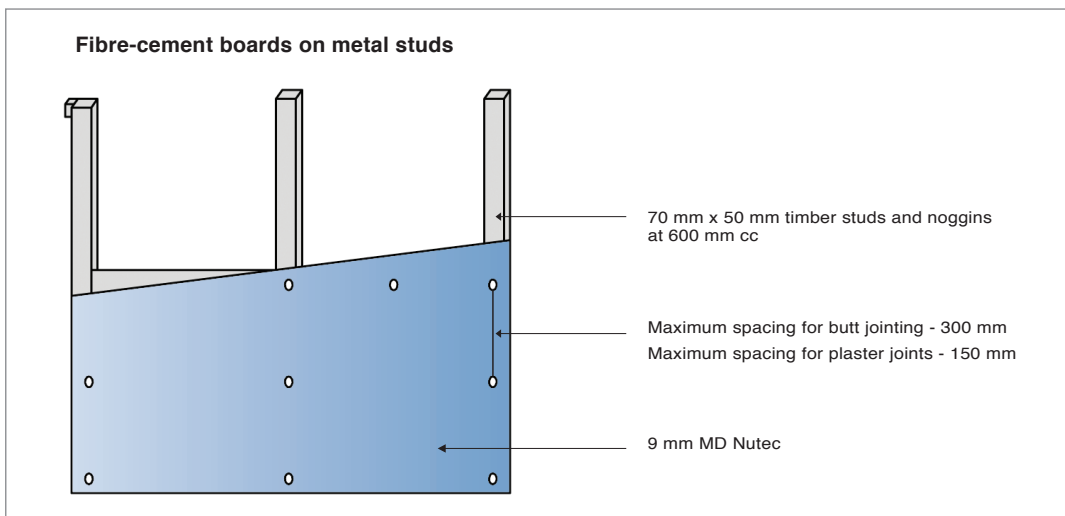
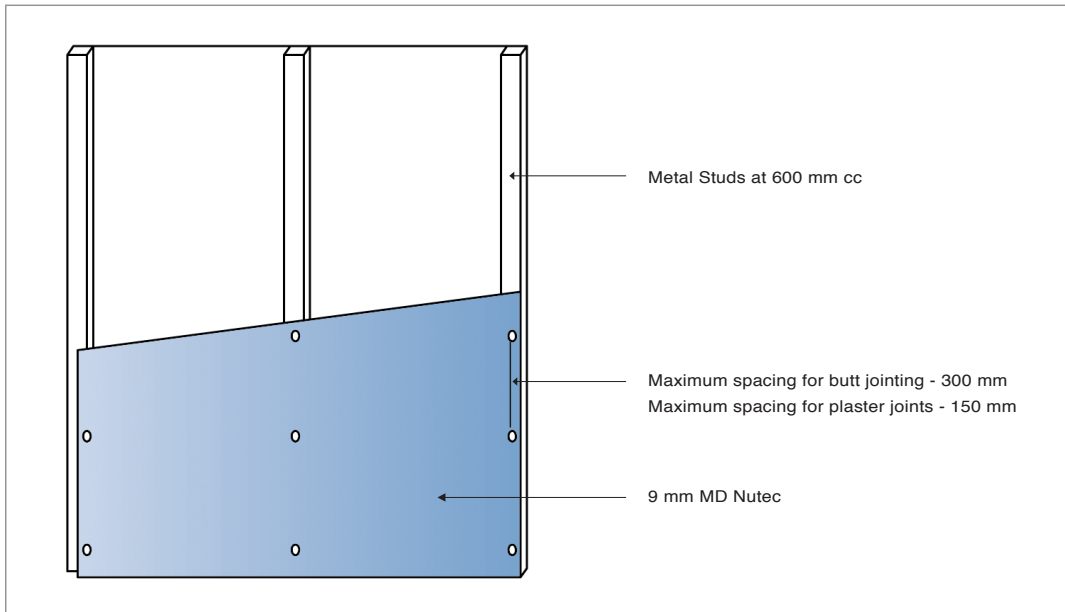

NB:

- Timber or steel framing may be used and should be constructed in accordance with local building regulations and acceptable building practice.
- Timber should be selected structural grade timber.
- Timber supports must be firmly secured to top and bottom plates and frames must not rely on the Nutec Flat Sheets for stability.
- Support spacings for external or internal walls should not exceed 600 mm centres.
- Framing members, should be arranged to support all sheet edges.
- Where the support faces behind sheet joints are less than 38 mm wide, pack out to provide additional landing for sheet fixing. *Refer Fig. 4.*
- For further information on timber framed structures, refer to SANS 10082.

INSTALLATION GUIDELINES AND FIXING DETAILS

Fixing of Nutec Flat Sheets to Support

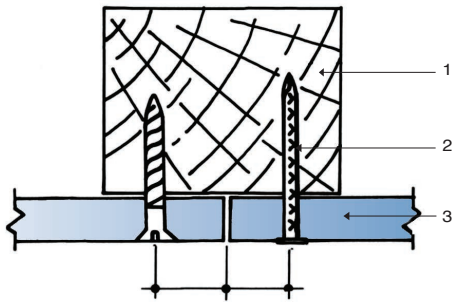

KEY

- | | |
|---|-------------------------------|
| 1 | Timber stud |
| 2 | Galvanised nail or wood screw |
| 3 | Nutec Flat Sheet |

Fixing of Nutec Flat Sheet to Narrow Support

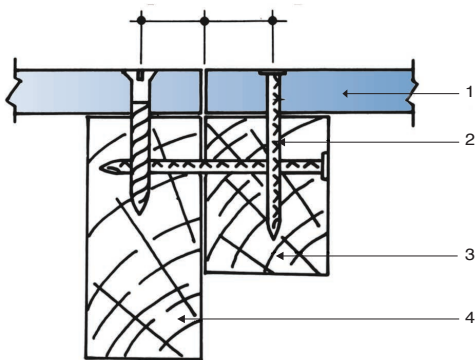

KEY

- | | |
|---|-------------------------------------|
| 1 | Nutec Flat Sheet |
| 2 | Galvanised nail or wood screw |
| 3 | Packing as required for narrow stud |
| 4 | Narrow stud |

■ Jointing

There are various methods that can be used for jointing.

Showing the Use of an H-profile Strip

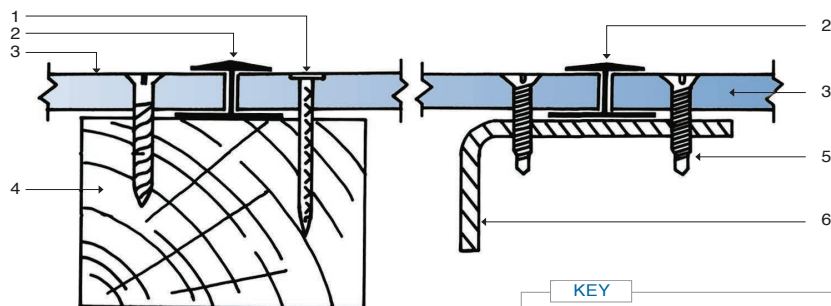

KEY

- | | |
|---|-------------------------------|
| 1 | Galvanised nail or wood screw |
| 2 | H profile jointing strip |
| 3 | Nutec Flat Sheet |
| 4 | Timber stud |
| 5 | Fixing screw |
| 6 | Metal frame |

TONGUE AND GROOVE INSTALLATION

Nutec Tongue and Groove Boards

Nutec Tongue and Groove Textured and Plain boards are medium density. These sheets are supplied in the natural grey and can be varnished with wood stain to simulate timber. Textured sheets can also be painted in various techniques to achieve a pleasant aesthetic finish. These boards are ideal for ceilings, internal and external wall panelling, door panelling and garden sheds.

Tongue and Groove Plain boards provide a classic smooth Tongue and Groove finish.

■ Fixing and Installation Details

| Guideline - Supporting Structure for Nutec Tongue and Groove Boards (Interior Application) | | |
|--|-------------------|---------------------|
| Maximim Span Between | | |
| Description and Thickness of Board | Vertical supports | Horizontal supports |
| 6 mm | 570 mm | 500 mm |
| 9 mm | 570 mm | 800 mm |

1. Cut the board to the correct size using a masonry cutting disk and place onto the wall in the desired position.
2. Drill 5 mm holes through the board at the fixing points and fasten the board to the wall using a 5 x 30 mm (minimum size) nail in screws with wall plugs. Cut nails can be used on plastered brick walls.
3. Make sure the screws are countersunk into the board when fastened.
4. Adjoining boards are butt joined together to simulate an extra 'groove' (5 mm apart).
5. Use crack filler to cover the screw heads and fill the butt joint leaving a smooth finish, (eg. Painter's mate).

Fig 20 : Flush, internal and external joints for Nutec Tongue and Groove Boards.

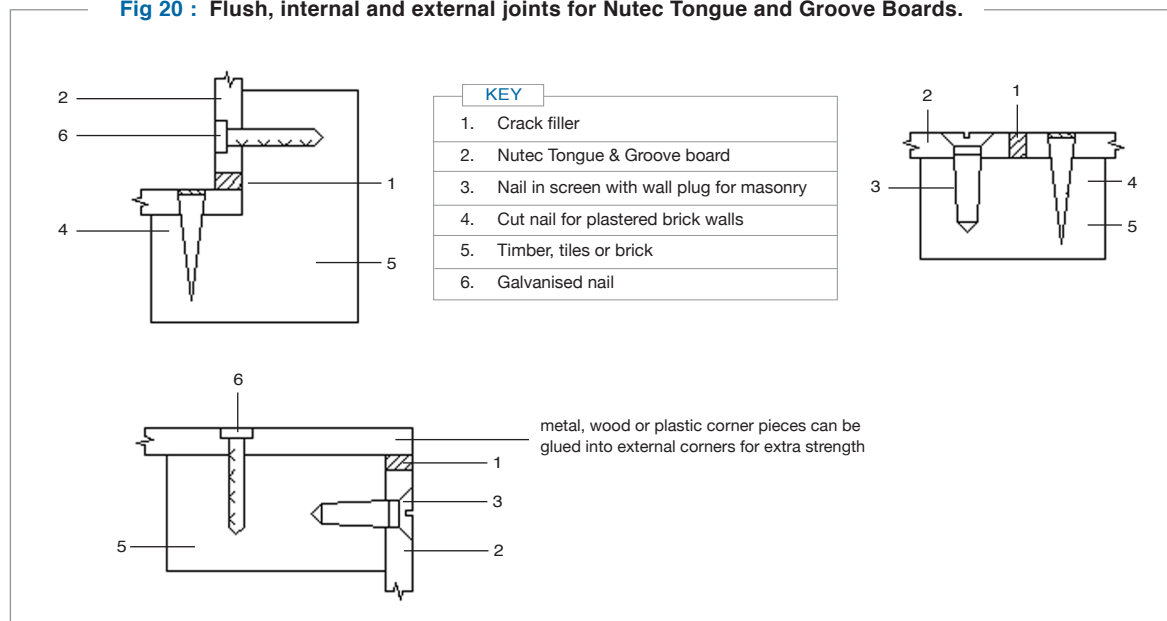

TONGUE AND GROOVE INSTALLATION

Fig 21 : Installing Nutec Tongue and Groove Board to even surfaces

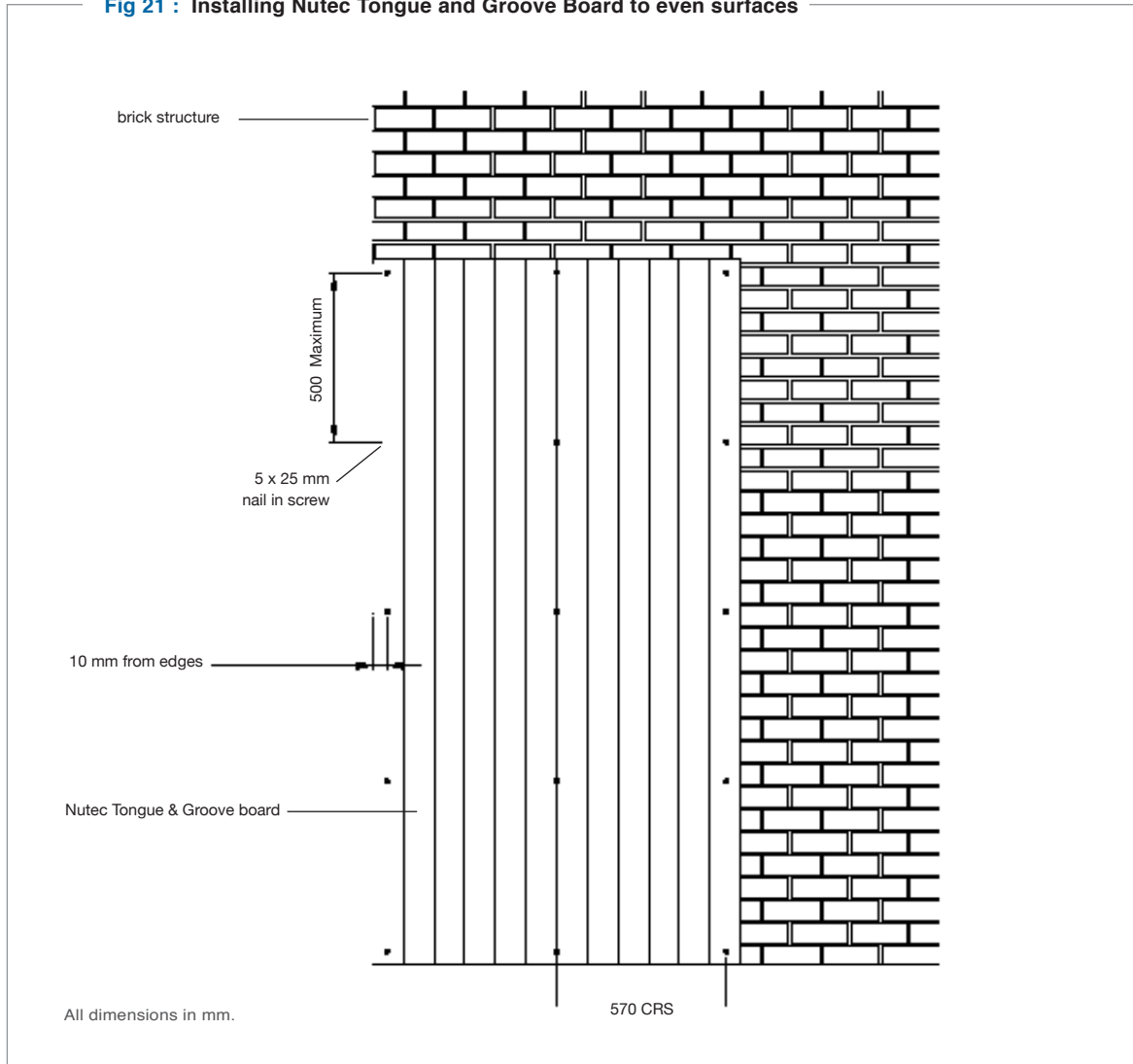

TONGUE AND GROOVE INSTALLATION

Fig 22 : Installing Nutec Tongue and Groove Board to uneven surfaces

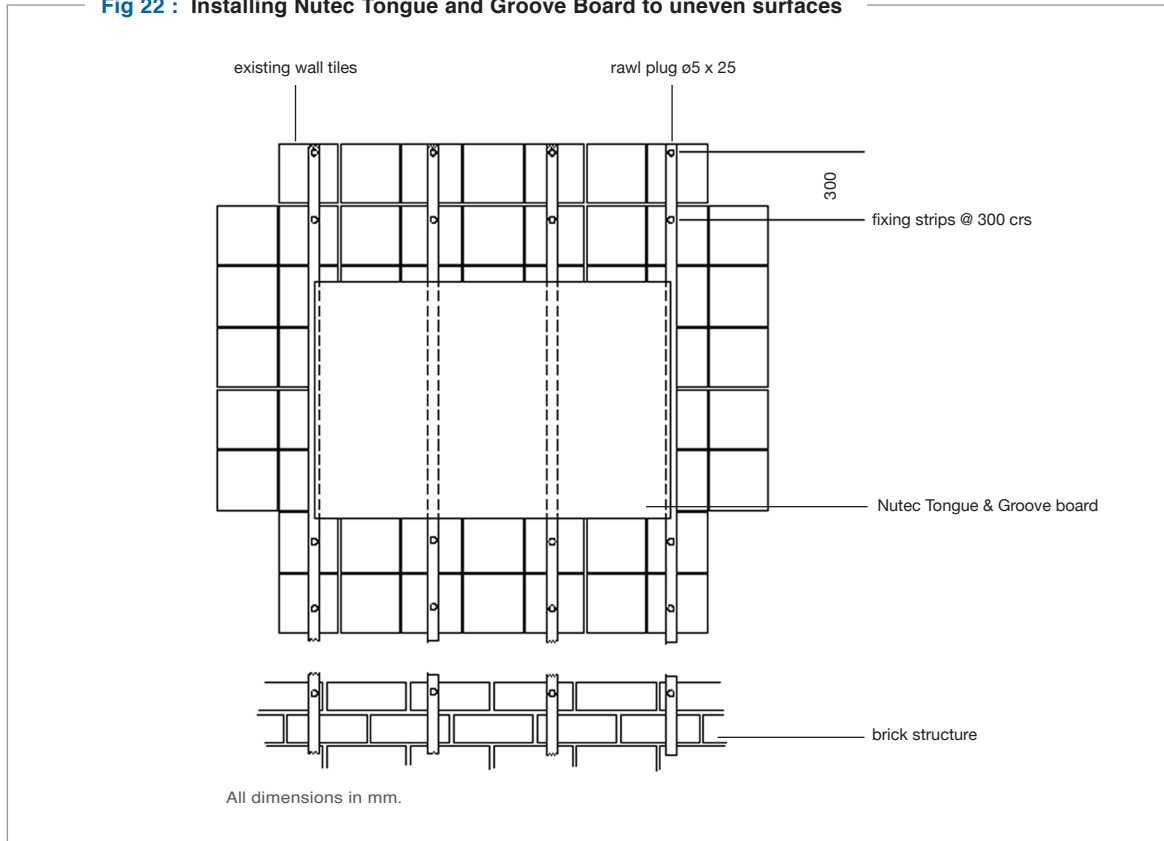

Things to remember when installing Nutec Tongue and Groove Boards.

- Nutec Tongue and Groove Boards may be applied to timber frames, plastered and unplastered walls and tiled surfaces as shown in [figure 21](#).
- Standard dado rails can be easily attached onto the wall above or below Tongue and Groove boards except when fixing strips are used. In such cases a shelf should be used instead.
- Fixing to uneven walls may required the use of fixing strips ([figure 22](#)) to ensure that the board remains flat and does not follow an uneven contour.
- Fixing strips must be fastened to the wall with nail in screws at 300 mm intervals. The irregularity of the wall will determine the thickness of timber used but a minimum of 15 mm should be adhered to.
- Spacer must be used at relevant fixing points behind the strips to compensate for the irregularities in the wall. A builders line must be used to draw a level across the strips.
- Nutec Tongue and Groove boards are attached to the fixing strips at the same intervals as they would normally be attached using.
- For ceiling applications these boards should be fixed at 600 m centers as shown in [figure 23](#).
- When used in wet areas, the board must be sealed continuously around the perimeter of the reverse side of the board 5mm from the edge.
- To form a double skin wall in a prefabricated steel or timber framed structure, the cavity between the two skins should be ventilated. In these structures, especially in humid conditions, foil is often

TONGUE AND GROOVE INSTALLATION

installed as a moisture barrier and as an insulator. Ventilating the cavity will permit the evaporation of any condensation which may collect on the insulating material. The sheets are best painted with a pure acrylic PVA paint. Where it is intended to use oil or alkyd paints it is essential to prime the sheet with an alkali-resistant sealer. In this instance both faces of the product should be sealed.

Fig 23 : Installing Nutec Tongue and Groove Boards as a Ceiling

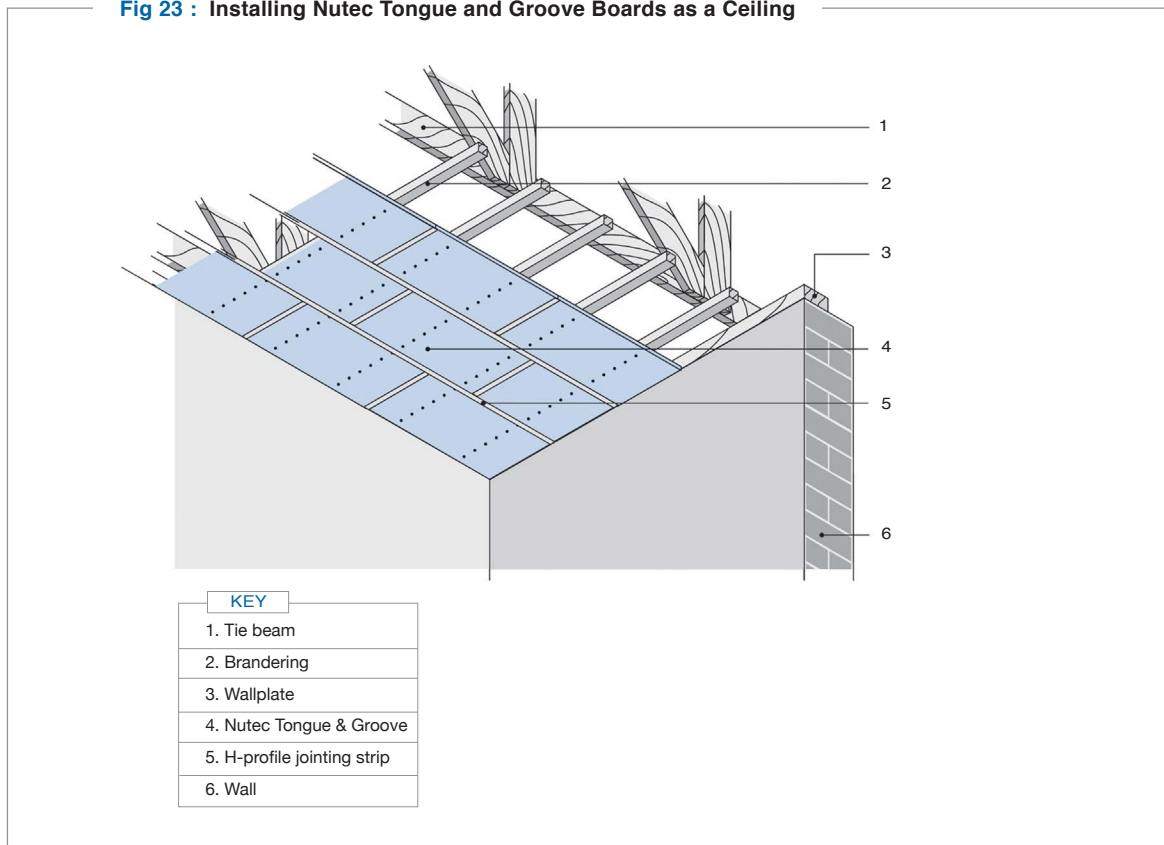

NB:

- Timber or steel framing may be used and should be constructed in accordance with local building regulations and acceptable building practice.
- Timber should be selected structural grade timber.
- Timber supports must be firmly secured to top and bottom plates and frames must not rely on the Nutec Flat Sheets for stability.
- Support spacings for external or internal walls should not exceed 600 mm centres.
- Framing members, should be arranged to support all sheet edges.
- Where the support faces behind sheet joints are less than 38 mm wide, pack out to provide additional landing for sheet fixing.
- For further information on timber framed structures refer to SABS 082 - the Code of Practice for Timber Buildings.

■ Floor / Ceiling Fire Resistant Systems

Fig 24 : General Plan of Arrangement of Floor/Ceiling 60 Minute Fire Rated System - Loading 1500 kN/m²

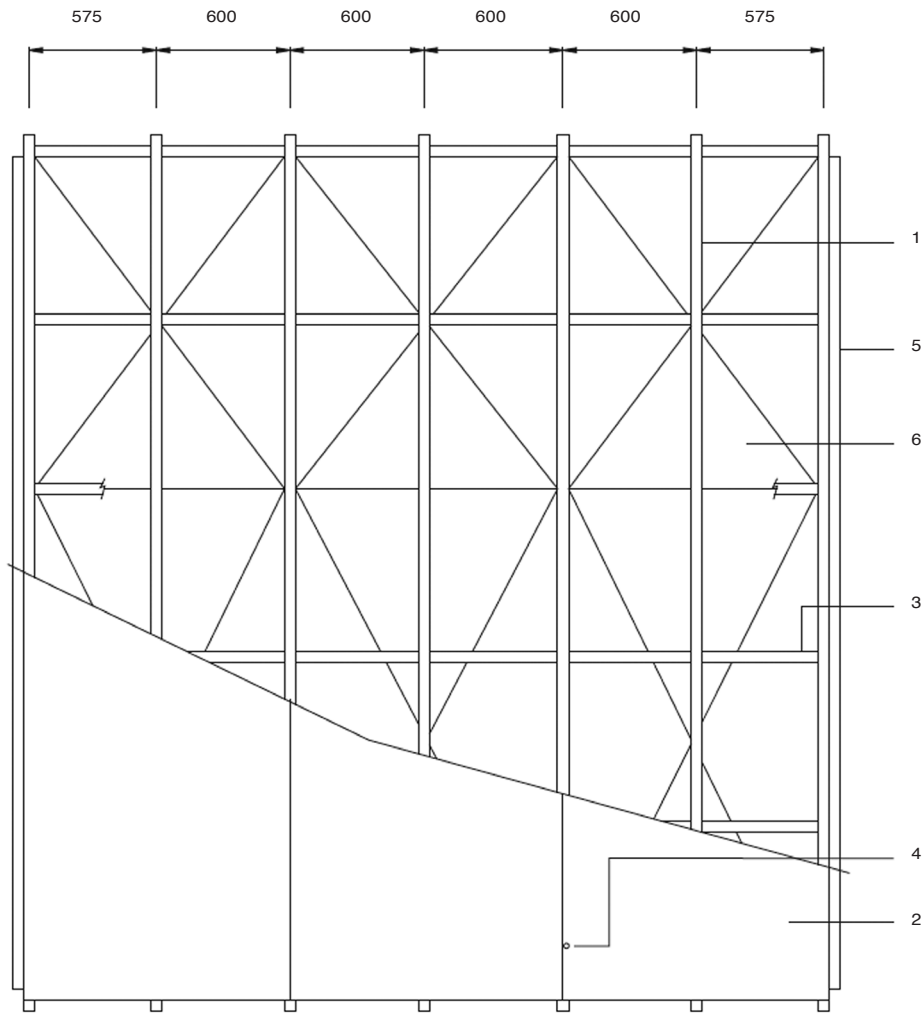

KEY

- | | |
|----|---|
| 1. | Softwood timber joists - 230 mm x 50 mm at 600 mm centre. |
| 2. | Floor Boards HD Nutec, 3600 mm x 1200 mm x 15 mm. |
| 3. | Softwood timber noggings at 600 mm centres by means of 100 mm nails. |
| 4. | 50 mm timber screws at 300 mm centres. |
| 5. | Mineral Fibre seal. |
| 6. | 6 mm Nutec Ceiling Board, 3600 mm x 1200 mm. Fixed with 50 mm timber screws at 300 mm centres to underside. |

Insulation: 50 mm Insulmate, 80 kg/m³.

Joints sealed with Intumex MA.

Screws and nail heads sealed with sodium silicate liquid.

Fig 25 : Typical 2-hour fire rated floor system

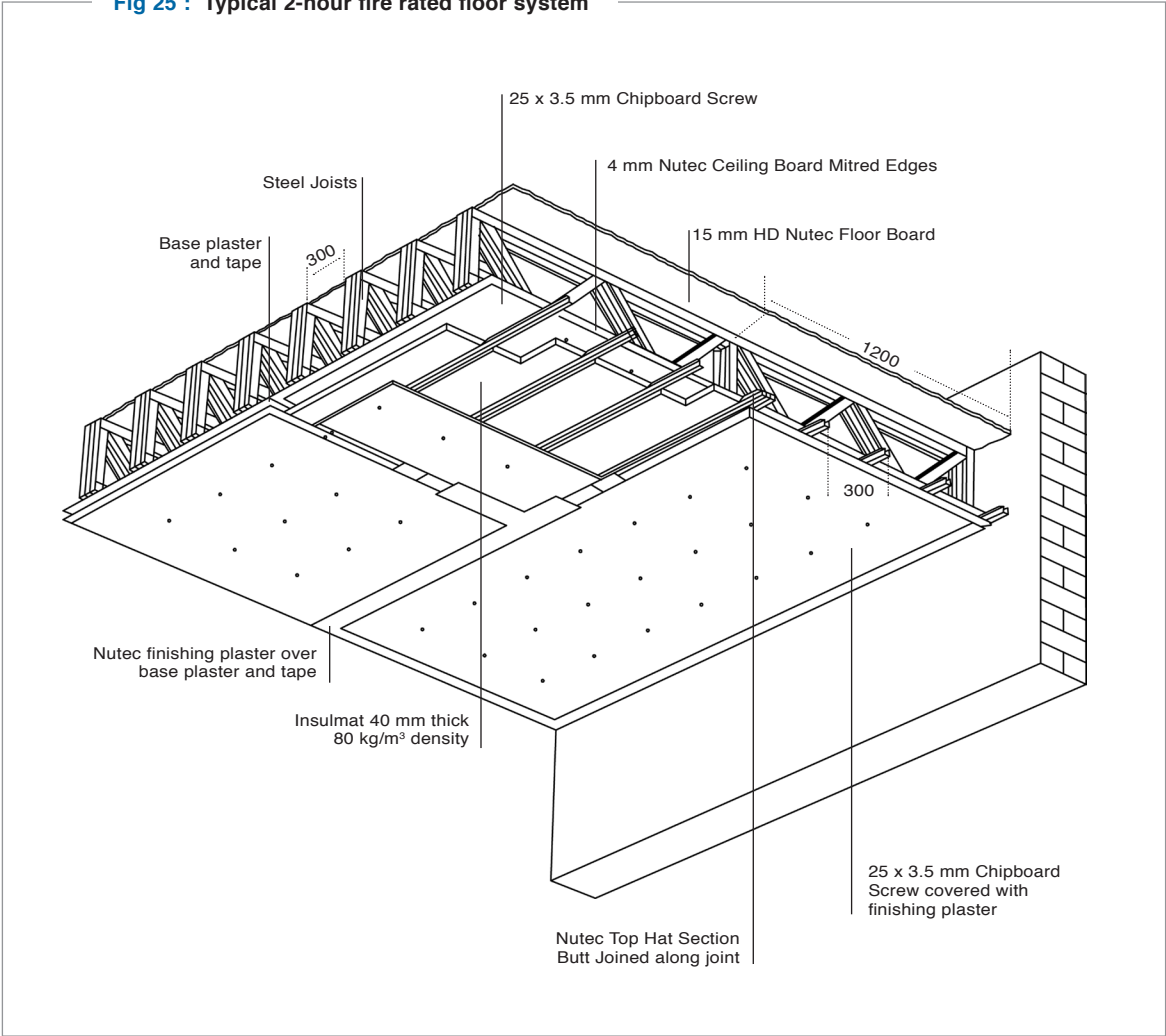

FIRE RESISTANCE SYSTEMS

Nutec Ceiling Boards in a suspended Floor System

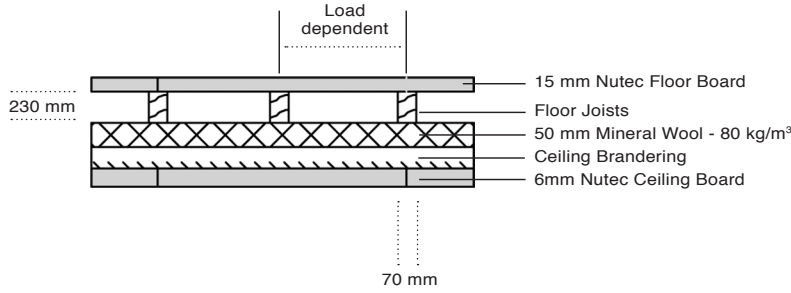
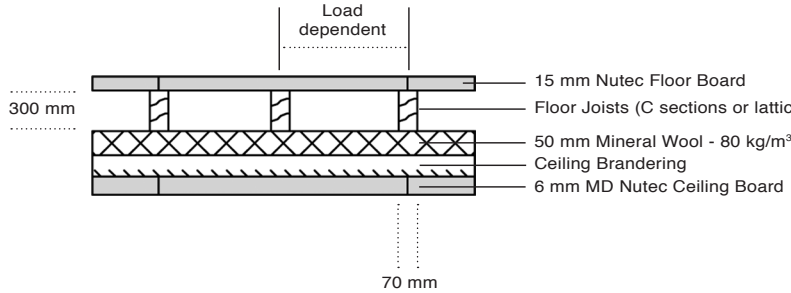
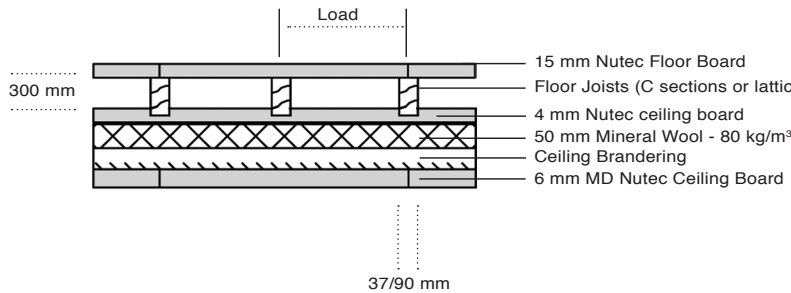
| Fire Resistance | Timber Support Systems |
|-------------------------|---|
| 60 minutes (structural) |  <p>Load dependent</p> <p>230 mm</p> <p>70 mm</p> <ul style="list-style-type: none"> 15 mm Nutec Floor Board Floor Joists 50 mm Mineral Wool - 80 kg/m³ Ceiling Branding 6mm Nutec Ceiling Board |
| Fire Resistance | Metal Support Systems |
| 30 minutes (structural) |  <p>Load dependent</p> <p>300 mm</p> <p>70 mm</p> <ul style="list-style-type: none"> 15 mm Nutec Floor Board Floor Joists (C sections or lattice) 50 mm Mineral Wool - 80 kg/m³ Ceiling Branding 6 mm MD Nutec Ceiling Board |
| 60 minutes (structural) |  <p>Load</p> <p>300 mm</p> <p>37/90 mm</p> <ul style="list-style-type: none"> 15 mm Nutec Floor Board Floor Joists (C sections or lattice) 4 mm Nutec ceiling board 50 mm Mineral Wool - 80 kg/m³ Ceiling Branding 6 mm MD Nutec Ceiling Board |

Nutec Board for Fire Rated Walling Systems

| Fire Resistance | Timber Frame Systems | Metal Frame Systems |
|-----------------------------|----------------------|---------------------|
| 30 minutes (non-structural) | | |
| 30 minutes (non-structural) | | |
| 60 minutes (non-structural) | | |
| 90 minutes (non-structural) | | |
| 90 minutes (non-structural) | | |

ACOUSTICAL AND THERMAL VALUES

■ Acoustical Insulation Walling Systems

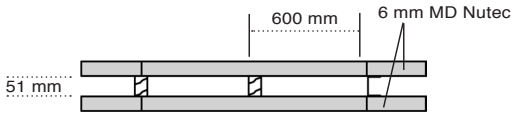
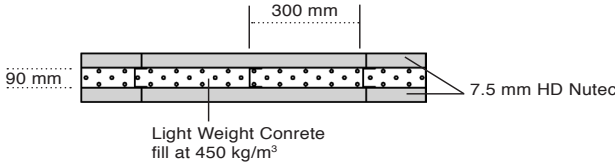
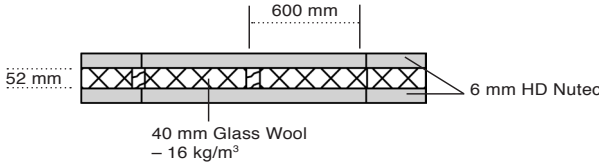
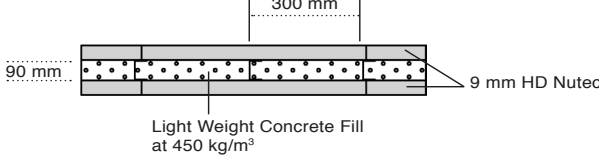
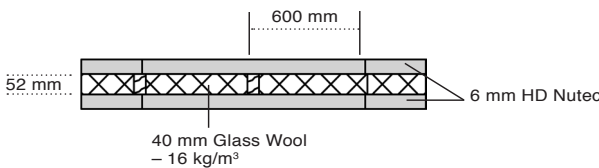
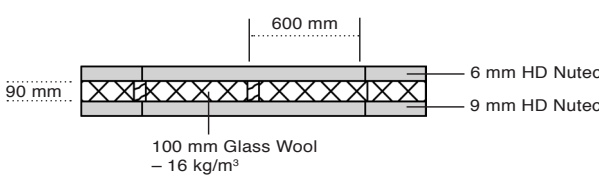
| Acoustical Performance | System Details Timber or Steel | Thermal Resistance |
|------------------------|--|-------------------------|
| 26.0 dB |  4 mm Unpressed Fibre-Cement | 0.02 m ² K/W |
| 35.7 dB |  51 mm 600 mm 6 mm MD Nutec | 0.06 m ² K/W |
| 44.0 dB |  90 mm 300 mm Light Weight Concrete fill at 450 kg/m ³ 7.5 mm HD Nutec | - |
| 44.8 dB |  52 mm 600 mm 40 mm Glass Wool - 16 kg/m ³ 6 mm HD Nutec | 1.06 m ² K/W |
| 45.0 dB |  90 mm 300 mm Light Weight Concrete Fill at 450 kg/m ³ 9 mm HD Nutec | - |
| 46.5 dB |  52 mm 600 mm 40 mm Glass Wool - 16 kg/m ³ 6 mm HD Nutec | 1.05 m ² K/W |
| 48.0 dB |  90 mm 600 mm 100 mm Glass Wool - 16 kg/m ³ 6 mm HD Nutec 9 mm HD Nutec | 2.56 m ² K/W |

ACOUSTICAL AND THERMAL VALUES

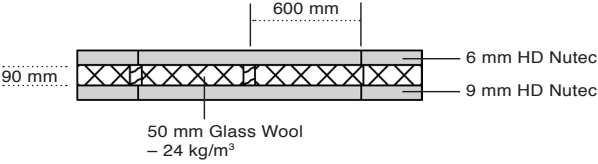
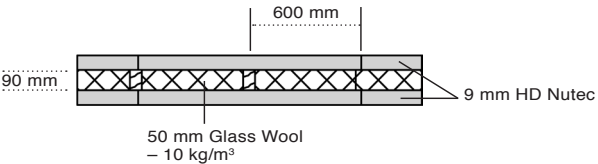
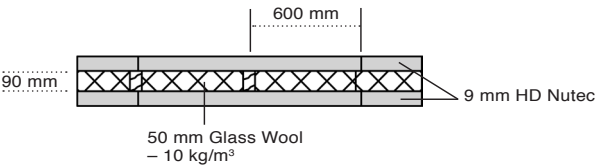
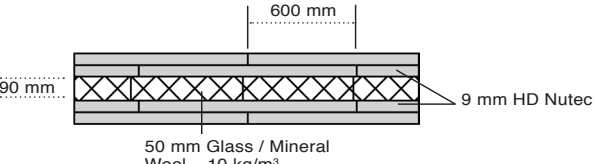
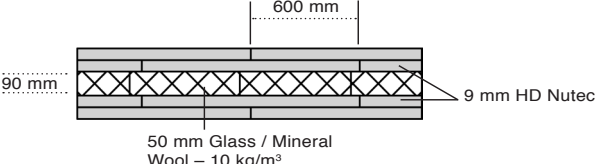
| Acoustical Performance | System Details Timber or Steel | Thermal Resistance |
|------------------------|---|-------------------------|
| 48.0 dB |  <p style="text-align: center;">600 mm</p> <p>90 mm</p> <p style="text-align: right;">6 mm HD Nutec 9 mm HD Nutec</p> <p style="text-align: center;">50 mm Glass Wool – 24 kg/m³</p> | 2.76 m ² K/W |
| 48.0 dB |  <p style="text-align: center;">600 mm</p> <p>90 mm</p> <p style="text-align: right;">9 mm HD Nutec</p> <p style="text-align: center;">50 mm Glass Wool – 10 kg/m³</p> | 1.44 m ² K/W |
| 49.0 dB |  <p style="text-align: center;">600 mm</p> <p>90 mm</p> <p style="text-align: right;">9 mm HD Nutec</p> <p style="text-align: center;">50 mm Glass Wool – 10 kg/m³</p> | 2.56 m ² K/W |
| 55.0 dB |  <p style="text-align: center;">600 mm</p> <p>90 mm</p> <p style="text-align: right;">9 mm HD Nutec</p> <p style="text-align: center;">50 mm Glass / Mineral Wool – 10 kg/m³</p> | 1.44 m ² K/W |
| 56.0 dB |  <p style="text-align: center;">600 mm</p> <p>90 mm</p> <p style="text-align: right;">9 mm HD Nutec</p> <p style="text-align: center;">50 mm Glass / Mineral Wool – 10 kg/m³</p> | 1.44m ² K/W |

MECHANICAL AND PHYSICAL PROPERTIES

Mechanical and Physical Properties

■ Plain and Textured Nutec Flat Sheets

| Parameter | Unit | High Density | Semi-High Density | Medium Density | Textured Nutec | Test Method |
|--|-------------------|----------------------|----------------------|----------------------|----------------------|-------------|
| Specifications | | | | | | |
| DIMENSIONS | | | | | | |
| Thickness Tolerance: | | | | | | |
| 9 mm | mm | - | ± 0.3 | ± 0.8 | ± 0.8 | SANS 803 |
| 10 mm | mm | ± 0.8 | - | - | - | SANS 803 |
| 12 mm | mm | - | ± 0.8 | - | - | SANS 803 |
| 15 mm | mm | ± 1.0 | - | - | - | |
| Length Tolerance: | | | | | | |
| All lengths | mm | ± 2 | +0 or -5 | +3 or -5 | +3 or -5 | SANS 803 |
| Width Tolerance: | | | | | | |
| All widths | mm | ± 2 | +0 or -2 | +3 or -5 | +3 or -5 | SANS 803 |
| Squareness | | | | | | |
| All sizes | mm | Maximum 5 | Maximum 2 | Maximum 5 | Maximum 5 | SANS 803 |
| Edge Trueness | | | | | | |
| All sizes | mm | Maximum 1 | Maximum 3 | Maximum 5 | Maximum 5 | SANS 803 |
| Physical Properties | | | | | | |
| Minimum MOR : | | | | | | |
| With Grain | MPa | 9.00 ⁽²⁾ | 8.44 ⁽¹⁾ | 7.40 ⁽¹⁾ | 7.40 ⁽¹⁾ | SANS 803 |
| Minimum MOR : | | | | | | |
| Across Grain | MPa | 13.00 ⁽²⁾ | 12.10 ⁽¹⁾ | 10.60 ⁽¹⁾ | 10.60 ⁽¹⁾ | SANS 803 |
| Target Density | g/cm ³ | 1.50 | 1.35 | 1.26 | 1.26 | ISO 8336 |
| Maximum Hygral Linear Expansion | mm/m | 2.47 | 2.47 | 2.47 | 2.47 | SANS 803 |

(1) Dried till constant weight (2) Saturated with water (3) Equilibrium conditions

MECHANICAL AND PHYSICAL PROPERTIES

| Parameter | Unit | High Density | Semi-High Density | Medium Density | Textured Nutec | Test Method |
|--------------------------------------|-------------------------|----------------------|----------------------|----------------------|----------------------|-----------------------------------|
| Typical Values | | | | | | |
| Thermal Conductivity | W/m.K | 0.30 | - | 0.19 | 0.19 | ASTM C518 |
| Thermal Expansion Coefficient | | | | | | |
| 20-70°C | °C-1 | Negligible | - | Negligible | Negligible | SANS Doc. 722/W 1009 |
| 10-70°C | °C-1 | 4.21 x 10-6 | - | 9.31 x 10-6 | 9.31 x 10-6 | ASTM C518 |
| Moisture Movement | | | | | | |
| With Grain | % | 0.30 | 0.053 | 0.06 | 0.06 | ASTM C1185 |
| Across Grain | % | 0.06 | 0.049 | 0.06 | 0.06 | ASTM C1185 |
| Moisture Content | % | 6.92 | 2.53 | 6.25 | 6.25 | ASTM C1185 |
| Water Absorption | % | 22.05 | 28.10 | 37.72 | 37.72 | ASTM C1185 |
| Permeability | - | No droplets | No droplets | No droplets | No droplets | SANS 685 ASTM C1185 BS 4624 |
| Water Vapour Transmission | ng /Pa.s.m ² | 97.154 | - | 276.79 | 276.79 | ASTM E96 |
| pH | | 10 -12 | 10 -12 | 10 -12 | 10 -12 | |
| Mechanical Properties | | | | | | |
| MOR : | | | | | | |
| With Grain | MPa | - | 6.20 ⁽²⁾ | 4.20 ⁽²⁾ | 4.20 ⁽²⁾ | ASTM C1185 |
| | MPa | 14.40 ⁽³⁾ | 11.20 ⁽³⁾ | 7.50 ⁽³⁾ | 7.50 ⁽³⁾ | ASTM C1185 |
| | MPa | - | 9.40 ⁽³⁾ | 11.20 ⁽³⁾ | 11.20 ⁽³⁾ | BS 4624 |
| MOR : | | | | | | |
| Across Grain | MPa | - | 8.40 ⁽²⁾ | 7.75 ⁽²⁾ | 7.75 ⁽²⁾ | ASTM C1185 |
| | MPa | 24.05 ⁽³⁾ | 18.50 ⁽³⁾ | 12.10 ⁽³⁾ | 12.10 ⁽³⁾ | ASTM C1185 |
| | MPa | - | 15.60 ⁽³⁾ | 16.40 ⁽³⁾ | 16.40 ⁽³⁾ | BS 4624 |

(1) Dried till constant weight (2) Saturated with water (3) Equilibrium conditions

MECHANICAL AND PHYSICAL PROPERTIES

| Parameter | Unit | High Density | Semi-High Density | Medium Density | Textured Nutec | Test Method |
|--|------|----------------------|-------------------|----------------------|----------------|-------------|
| Specifications | | | | | | |
| Classification in Accordance to ASTM C1186 | - | II | I | I | I | |
| Compressive Strength Parallel to Surface of Board | | | | | | ASTM C1186 |
| With Grain | MPa | 15.21 | - | 10.86 ⁽²⁾ | - | ASTM D1037 |
| | MPa | 24.62 | - | 15.57 ⁽³⁾ | - | ASTM D1037 |
| Across Grain | MPa | 20.61 | - | 11.54 ⁽²⁾ | - | ASTM D1037 |
| | MPa | 37.22 ³ | - | 19.58 ⁽³⁾ | - | ASTM D1037 |
| Tensile Strength Parallel to Surface of Board | | | | | | |
| With Grain | MPa | 3.47 ⁽²⁾ | - | 2.11 ⁽²⁾ | - | ASTM D1037 |
| | MPa | 5.12 ⁽³⁾ | - | 3.26 ⁽³⁾ | - | ASTM D1037 |
| Across Grain | MPa | 4.34 ⁽²⁾ | - | 2.24 ⁽²⁾ | - | ASTM D1037 |
| | MPa | 5.95 ⁽³⁾ | - | 2.88 ⁽³⁾ | - | ASTM D1037 |
| Tensile Strength Parallel to Surface of Board | | | | | | |
| | MPa | 1.42 ⁽²⁾ | - | 0.83 ⁽²⁾ | - | ASTM D1037 |
| | MPa | 2.18 ⁽³⁾ | - | 1.02 ⁽³⁾ | - | ASTM D1037 |
| Young's Modulus (E.Mod) | | | | | | |
| With Grain | MPa | 9898 ⁽³⁾ | - | 5337 ⁽³⁾ | - | ASTM C120 |
| | MPa | 7747 ⁽²⁾ | - | 3974 ⁽²⁾ | - | ASTM C120 |
| Across Grain | MPa | 11645 ⁽³⁾ | - | 6474 ⁽³⁾ | - | ASTM C120 |
| | MPa | 7903 ⁽²⁾ | - | 4681 ⁽²⁾ | - | ASTM C120 |
| Block Shear Strength | | | | | | |
| | MPa | 3.30 ⁽³⁾ | - | 1.60 ⁽²⁾ | - | ASTM D143 |
| | MPa | 3.17 ⁽²⁾ | - | 1.32 ⁽³⁾ | - | ASTM D143 |

(1) Dried till constant weight (2) Saturated with water (3) Equilibrium conditions

MECHANICAL AND PHYSICAL PROPERTIES

| Parameter | Unit | High Density | Semi-High Density | Medium Density | Textured Nutec | Test Method |
|--|-------|--------------|-------------------|----------------|----------------|--------------------------------------|
| Fire Properties | | | | | | |
| Surface Spread of Flame | Class | 1 | 1 | 1 | 1 | SANS 10177: Part 111, BS 476: Part 7 |
| Spread of Flame Index | - | Nil | Nil | Nil | Nil | SANS 10177 Part III |
| Heat Contribution Index | - | Nil | Nil | Nil | Nil | SANS 10177 Part III |
| Smoke Emission Index | - | Nil | Nil | Nil | Nil | SANS 10177 Part III |
| Surface Fire Index | - | Nil | Nil | Nil | Nil | SANS 10177 Part III |
| Surface Burning Characteristics | | | | | | |
| FSI (Flame spread index) | - | 0 | - | 0 | 0 | ASTM E84 |
| SD (Smoke developed index) | - | 5 | - | 3 | 3 | ASTM E 84 |
| Non-Combustibility | | Non-combus. | Non-combus. | Non-combus. | Non-combus. | BS 476 Part 4, SANS 10177: Part V |
| Continuous Temperature | - | 150°C | 150°C | 150°C | 150°C | - |

(1) Dried till constant weight (2) Saturated with water (3) Equilibrium conditions

MECHANICAL AND PHYSICAL PROPERTIES

| Parameter | Unit | High Density | Semi-High Density | Medium Density | Textured Nutec | Test Method |
|---|-------|--------------|-------------------|----------------|----------------|-------------|
| Other Properties | | | | | | |
| Frost Resistance Cycles Completed | - | 50 | - | 50 | - | ASTM C1185 |
| Strength Ratio | % | 97.5 | - | 78.5 | - | ASTM C1185 |
| Biological Resistance Rodent Resistance | Class | B1 | - | B1 | - | SANS 5417 |
| Termite Resistance | | No Damage | - | No Damage | - | SANS 5471 |
| Resistance to Bacteria | | - | - | No Growth | - | BS 5980 |

(1) Dried till constant weight (2) Saturated with water (3) Equilibrium conditions

CONTACT DETAILS

EVERITE NATIONAL OFFICE

Call Centre + 27 11 439 4400
www.everite.co.za



OTHER REGIONS

Sales Support Office

Telephone + 27 11 439 4400

Bloemfontein

Mobile 083 798 8049

Cape Town

Telephone + 27 21 981 5212

Durban

Telephone + 27 31 701 0959

East London

Mobile + 27 79 516 6510

George

Telephone + 27 44 873 2408

Mobile + 27 83 286 3435

Middelburg (Mpumalanga)

Mobile + 27 83 778 2787

Polokwane

Telephone + 27 15 297 3559

+ 27 15 297 3560/1

Port Elizabeth

Telephone + 27 41 451 0655

Mobile + 27 83 780 6162

Worcester

Telephone + 27 21 981 5212

Mobile + 27 83 286 3429

Botswana (Gaborone)

Telephone + 27 11 439 4400

Namibia

Mobile + 264 81 124 2655





www.everite.co.za
call centre: 0861 333 835

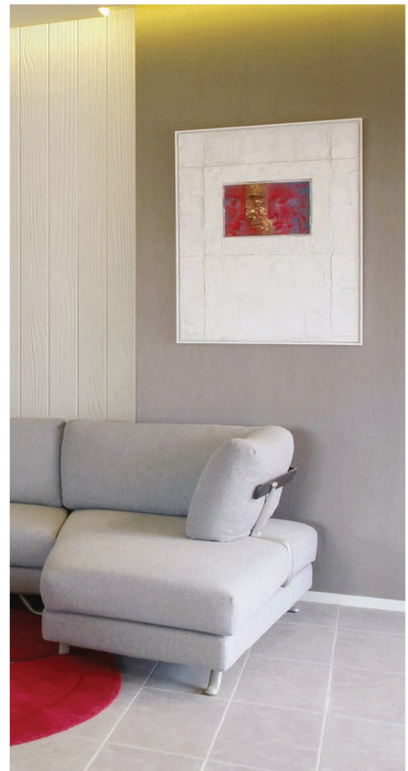

Copyright © 2012
Everite Building Products (Pty) Ltd.
All rights reserved.